



SHINING 3D



EinStar Rockit

V1.0.6

User Manual

Table of Contents

Overview

- Welcome**
- Quick Start Guide**

Introduction

- Device Introduction**
- Installation**
- Device Activation**
- Home Screen**
- Upgrade**
- Device Connection**
- 3Dconnexion SpaceMouse**

Calibration

- Notice**
- Operation**

Scan Modes

Scan

- Project Group**
- Project Group Settings**
- Project Management**
- Scan Preparation**
- Scan Interface**
- Settings**
- Scanning**
- Data Editing**
- Project Alignment**

Post-Processing

Mesh

Mesh Editing

Measurement

Measurement

Creating Features

Model Alignment

Measurement Tools

Save and Share

Version History



Contact

Overview

Welcome

This user manual (hereinafter referred to as "this manual") mainly introduces the appearance and operation of the **Einstar Rockit** and the operation of the EXStar Hub.

Symbol Conventions

Symbol	Meaning
	Note: This symbol is used to inform you of the additional information of the product.
	Caution: This symbol is used to inform you of incorrect operations that may damage the device or result in data loss. Any damages resulting from misuse are not covered by the warranty.
	Warning: This symbol is used to inform you of the potential risks that may result in serious personal injury and other safety incidents.

The Declaration of Intellectual Property and Disclaimer

Thank you for using the products of SHINING 3D TECH CO., LTD. (hereinafter referred to as the "SHINING 3D"). Before you use the products, please carefully read and understand this declaration. Once you use this product, it means that you fully accept this statement and promise to comply with the relevant regulations.

1. The contents of the Product Instruction and User Manual (hereinafter collectively referred to as the "Product Usage Documentation") are critical to your personal safety, legal rights, and liabilities. Before you use the products, please ensure that you have carefully read the Product Usage Documentation, and use the product correctly in accordance with the requirements of the Product Usage Documentation. We also recommend that the products be operated by trained professional technicians.
2. Please inspect and/or maintain the product before use. If the product is damaged, deformed or in any other abnormal condition, stop using it immediately and contact the after-sales service personnel for maintenance. SHINING 3D will not be responsible for any problems caused by your failure to inspect or maintain the product in a timely manner.
3. SHINING 3D does not guarantee the applicability of the outcomes of your use of the products, and you are responsible for verifying the quality and functionality of the outcomes. You should check and verify thoroughly that any outcomes meet your requirements before using them, for which you bear full responsibility. If any damage arising from using the outcomes of any products, you shall bear the corresponding risk, and SHINING 3D shall not bear any responsibility.

4. SHINING 3D owns complete intellectual property rights for the contents of the Product Usage Documentation for which you bear full responsibility. Without the written consent of SHINING 3D, it is not allowed to copy, transmit, publish, adapt, compile or translate any contents of the Product Usage Documentation in any form for any purpose.
5. The Product Usage Documentation is a guidance for installing, operating, and maintaining the product instead of serving as the quality guaranty for the products. SHINING 3D makes all efforts to ensure the applicability of the Product Usage Documentation, but reserves the right of final interpretation. Images and diagrams in the product documentation are presented to provide convenience to user understanding. In the event that any images or diagrams are inconsistent with the physical products, the latter shall prevail. In addition to the mandatory provisions of laws and regulations, the contents of the Product Usage Documentation are subject to changes without further notice.
6. SHINING 3D shall not be held responsible for any damages and/or losses caused by human factors, environmental factors, improper storage and use, or any other factors other than due to the quality of the product. SHINING 3D also shall not be held responsible for any indirect anticipated profit loss, loss of reputation and other indirect economic losses. Except as otherwise expressly provided by laws and regulations, the total liability assumed by SHINING 3D (regardless of cause) shall not exceed the purchase price of the products you paid to SHINING 3D.
7. Disputes arising from this Declaration and the Product Usage Documentation thereof shall be governed by the laws of the People's Republic of China, excluding its conflict of law rules. In the event that certain provisions are in conflict with the applicable law, these provisions will be reinterpreted in full accordance with the law, while other valid provisions will remain in force.
8. All disputes between you and SHINING 3D about the Product Usage Documentation shall first be resolved amicably through negotiation. If a dispute cannot be resolved through friendly negotiation, any party may submit the dispute to the Court of Xiaoshan District, Hangzhou City, Zhejiang Province, People's Republic of China for litigation and settlement.
9. In the event of any questions about the contents of this Declaration and application of Product Usage Documentation, please contact us by the contact information provided in the User Manual. Thank you for your cooperation and support! We hope that our products can bring you a great experience of using.

Quick Start Guide

This chapter provides an overview of **EXStar Hub V1.0.6** to help you quickly find relevant operation instructions. If you are using another version, please refer to the corresponding user manual in the [history version](#).

How to download the software?

Please log in to [Download Center](#)[□], select the software to download; for more details, see [Installation](#).

How to check the current software version?

Click  in the upper-right corner > **About** to view the current software version.

If your device is not connected, you can only use EXStar Hub to import projects for post-processing or measurement. To use scanning functions, connect your device first.

How to connect devices?

Both wireless and wired connections are supported. For detailed instructions, please refer to [Device Connection](#).

How to activate devices?

The device can only be activated when connected to a wired connection. For detailed instructions, please refer to [Device Activation](#).

Home Screen

Basic settings, connecting or disconnecting devices, creating projects, viewing projects, and other operations can be performed on the home screen. For details, please refer to [Home Screen](#).

If you are using the device for the first time or have not recalibrated it for a long time, please calibrate it after connecting the device via cable.

Calibration

This device supports camera calibration and white balance calibration.

Camera Calibration: Perform [camera calibration](#) when using the device for the first time, after a long time without recalibrating, or after changing the calibration board.

White Balance Calibration: Perform [white balance calibration](#) before texture scanning or when there is a discrepancy between the scanned texture and the actual texture.

After the device is activated and connected, operate the device according to the following steps.

1 Create or Open a Project Group

Before scanning, select a file storage path and create a project group. Alternatively, import a previously scanned project group from the same device to continue scanning.

→ [How to create or open a project group?](#)

→ [How to configure project group settings?](#)

2 Configure Scanning Parameters

After creating a project group, you can configure scanning parameters before starting to improve scanning results and experience.

→ [How to configure scanning parameters?](#)

→ [How to operate on a single project after creating/opening a project group?](#)

[3] Scanning

Perform scanning.

→ [What preparations are needed before scanning?](#)

→ [Introduction to the scan interface](#)

[4] Data Editing

You can edit scanned data after pausing scanning to reduce noise and obtain precise data.

→ [Editing toolbar introduction](#)

→ [Cutting plane tool introduction](#)

→ [Right sidebar introduction](#)

→ [Shortcut keys introduction](#)

→ [Context menu introduction](#)

→ [How to align projects?](#)

[5] Save and Export Data

You can save scanned data for future import or export.

→ [How to save and share data?](#)

[6] Post-Processing and Measurement

You can process or measure scanned data.

→ [How to configure mesh parameters?](#)

→ [What optimization operations are available after meshing?](#)

→ [How to create features in the measurement interface for further operations?](#)

→ [How to align scanned data in the measurement interface?](#)

→ [How to measure scanned data in the measurement interface?](#)

Introduction

Device Introduction

The Einstar Rockit features a built-in Wi-Fi module and a marker-free workflow, allowing for scanning anytime and anywhere. Its dual light sources, compact body, and intelligent audio feedback make 3D scanning simpler and more convenient. Whether you are a designer, artist, engineer, or manufacturer, Rockit is your go-to tool for 3D scanning in fields such as automotive, digital art, and AR/VR.

Packing List

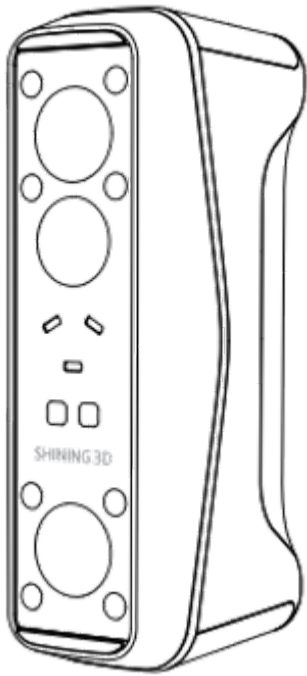

EinStar Rokkit 3D Scanner

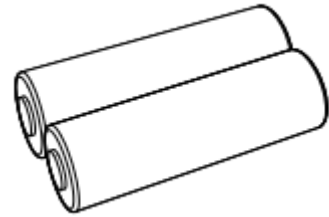

Battery

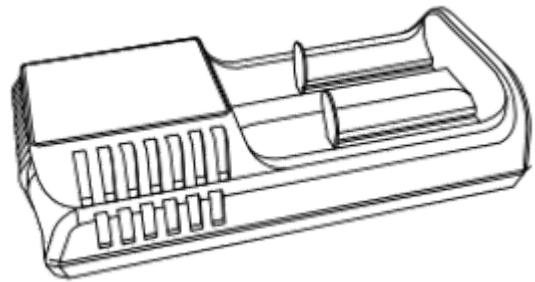

Battery Compartment

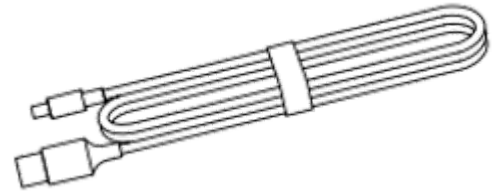

Battery Compartment Charging Cable



Universal Holder (Calibration Board)

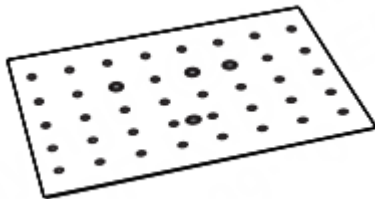

Calibration Board

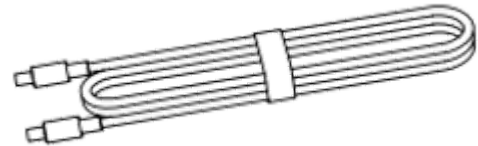

Type-C Cable for Scanner and Battery Compartment

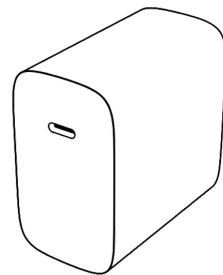

Power Adapter

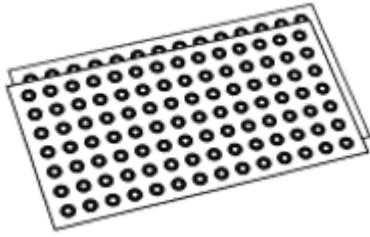

3 mm and 6 mm Reflective Markers Set

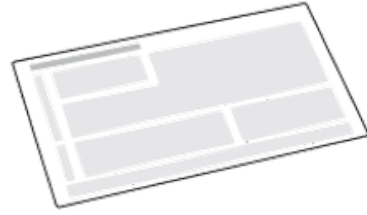

Packing List

Battery Specifications and Requirements

Specification	Description
Type	Rechargeable Lithium-ion Battery
Length	75.4 ± 0.3 mm
Diameter	21.7 ± 0.3 mm
Nominal Voltage	3.6 V
Capacity	5500 mAh
Cycle Life	Over 400 times

Operating and Storage Requirements	Description
Operating Temperature	Charging: 0 ~ 45°C Discharging: -20 ~ +60°C
Storage / Transport Temperature	-20 ~ +45°C (less than 1 month) -20 ~ +35°C (less than 3 months) -20 ~ +25°C (less than 6 months)
Storage / Transport Relative Humidity	≤ 75%RH

Device Structure and Composition

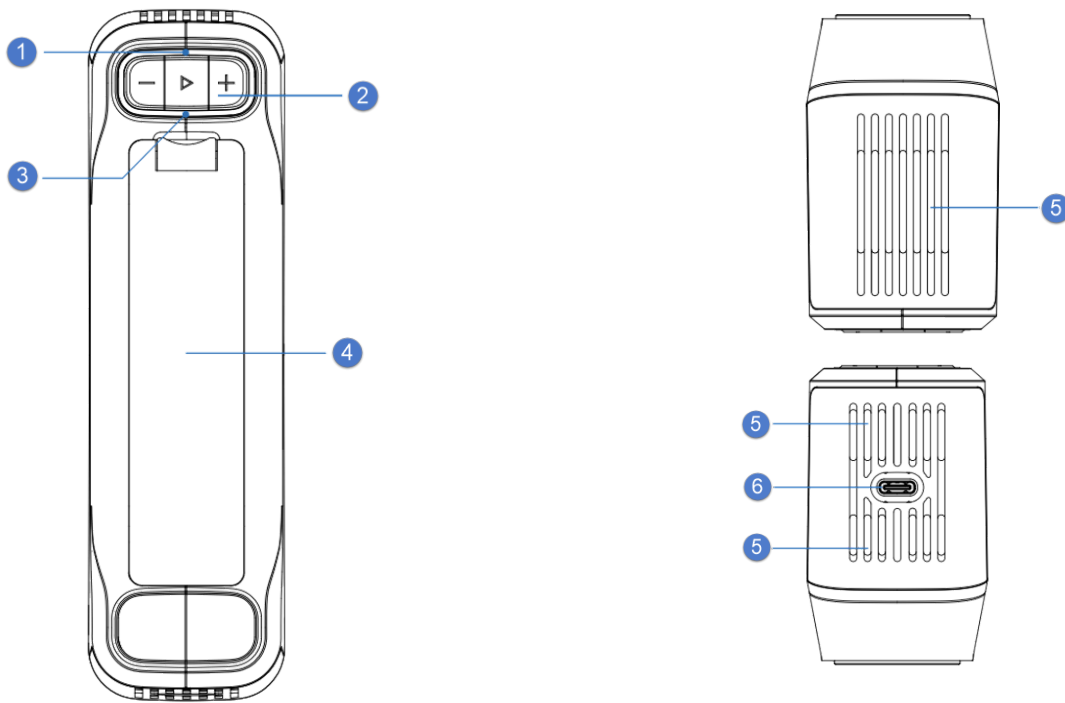

① Status Indicator Light

This indicator light shows the device's connection status or scanning status.

Non-scanning Status

- Blue (flashing): The device is not connected to software.
- Green (steady): The device is connected to software.
- Yellow (flashing): Firmware is updating.



Scanning Status

- Blue (steady): The scanning distance is too far.
- Light Blue (steady): The scanning distance is farther away.
- Green (steady): The scanning distance is appropriate.
- Yellow (steady): The scanning distance is close.
- Red (steady): The scanning distance is too close.

② Function Button





▶ The button controls power on/off, starts calibration, switches scanning status and light sources, and brings up the menu.

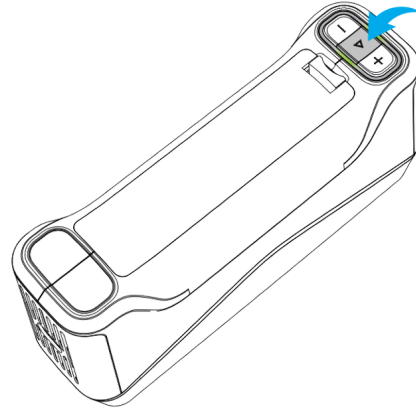



- Long press  for about 2 seconds until the status indicator and battery indicator light up, indicating the device is powered on.
- Long press  for about 5 seconds until the indicators turn off, indicating the device is powered off.
- Calibration interface: Press  to start calibration.



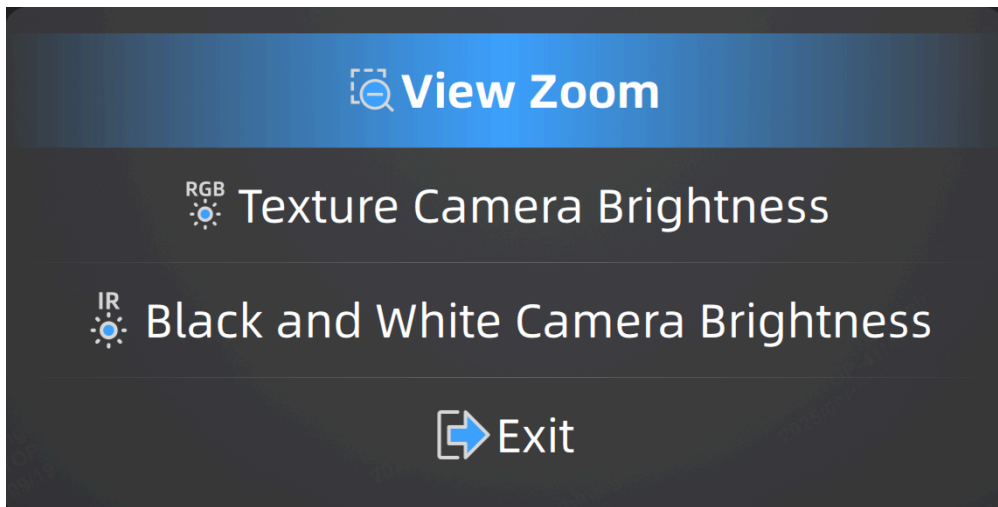

Scanning interface:

- Press  to start scan preview; multiple presses cycle through scan preview, scanning, and pause scanning states.
- Press  twice to bring up the menu and select the control range for the  /  buttons (black and white camera brightness adjustment, texture camera brightness adjustment, or view zoom).



- Long press  to quickly switch light source modes (cross lines or parallel lines).

 /  buttons control the brightness increase or decrease of the black and white camera and texture camera, or the zoom size of the view.

- Press **+** / **-** to increase or decrease camera brightness or zoom in or out of the model view.
- Press **+** / **-** twice directly changes to the highest/lowest brightness level or the maximum/minimum state of the model view.
- Long press **+** / **-** to continuously increase or decrease camera brightness or continuously zoom in or out of the model view.

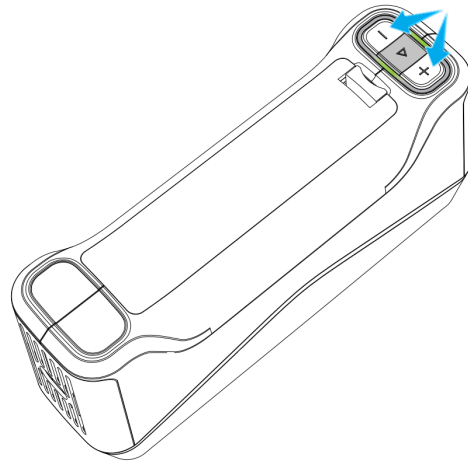

③ Battery Indicator Light

- Green (steady): Battery level > 50%.
- Yellow (steady): 10% < Battery level ≤ 50%.
- Red (steady): Battery level ≤ 10%.

Note

When the device is connected to a Type-C cable for charging, the battery indicator light will change from steady to breathing state.

- Yellow (flashing): Abnormal state, unable to read battery information.
- Red (flashing): Current device temperature is too high or battery level is too low.

④ Battery Compartment

Open the battery compartment to insert the battery.

Caution

Please insert the battery correctly according to the indicated positive and negative directions.

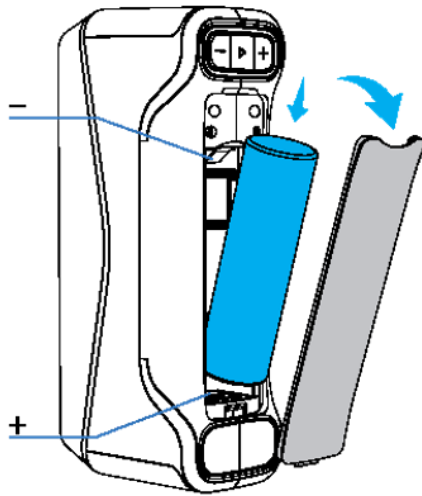

⑤ Air Vents

The device's air vents should not be blocked while the device is in operation.

⑥ USB Type-C Port

Connect the device to a computer using a Type-C cable for wired scanning or charging.



Installation

Before using the scanner, you need to install the EXStar Hub software (hereinafter referred to as "software").

Operating Environment

Recommended Configuration	
Processor	13th Gen Intel® Core™ i7-13700H or higher
Graphics Card	NVIDIA GeForce RTX 3060 Laptop GPU or higher
VRAM	6 GB or higher
RAM	32 GB or higher, DDR5 dual-channel
Interface	USB 3.0
Operating System	Windows 10 Pro (64-bit) and Windows 11 Pro (64-bit)



Note

The current version only supports NVIDIA graphics cards.

Download

Please log in to [Download Center](#)[🔗], select the software to download, and complete the installation according to the software installation wizard.



Note

During the software installation, **TeamViewer** is selected by default for bundled installation. After installation, launch the software and click  > **Support** > **Remote Assistance** to initiate **TeamViewer**. If remote assistance is not needed, uncheck the **TeamViewer** option during installation to prevent automatic installation of TeamViewer along with the software. You can later download TeamViewer independently via the [TeamViewer official website](#)[🔗].

Device Activation

When using the device for the first time, please perform **online activation** after starting the software; otherwise, the calibration and scanning functions will be unavailable.

Online Activation

Upon the first launch of the software, you can register an account and log in on the automatically popped-up passport interface to activate the device.

If you have not logged into your passport this time, you can activate it later through the activation entrance at the upper left corner of the [home screen](#) or log into the passport by clicking  at the upper right corner of the interface.

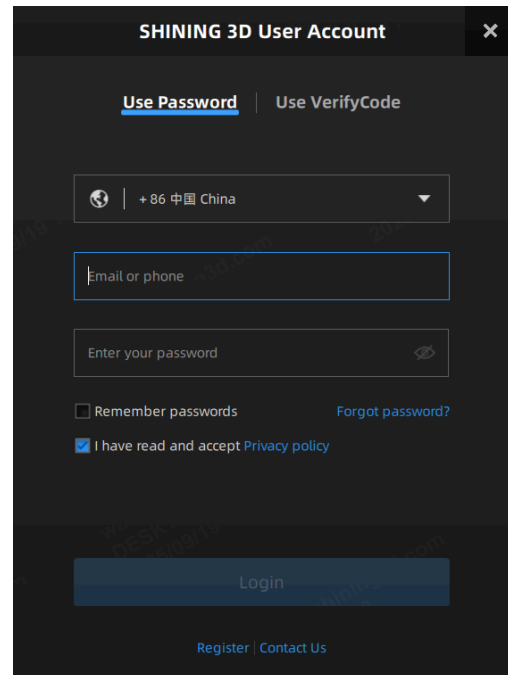

Note

- The warranty period starts after activation.
- Please activate the device while it is [wired connected](#).
- Before activating the device, please ensure that the computer is connected to a network.

Guest Mode

If you do not wish to log into the passport for now, you can choose to use the software in guest mode.

Note

- If the device activation is not completed and you do not log into the passport, you can only edit the data in the post-processing and measurement interface.
- If the device activation is completed and you do not log into the passport, you can still use all functions of the software, but uploading project data to the SHINING 3D Cloud will be unavailable.

Home Screen

After running the software, you will automatically go to the home screen. You can access recent files, create or open project groups, and quickly navigate to other interfaces.

Overview

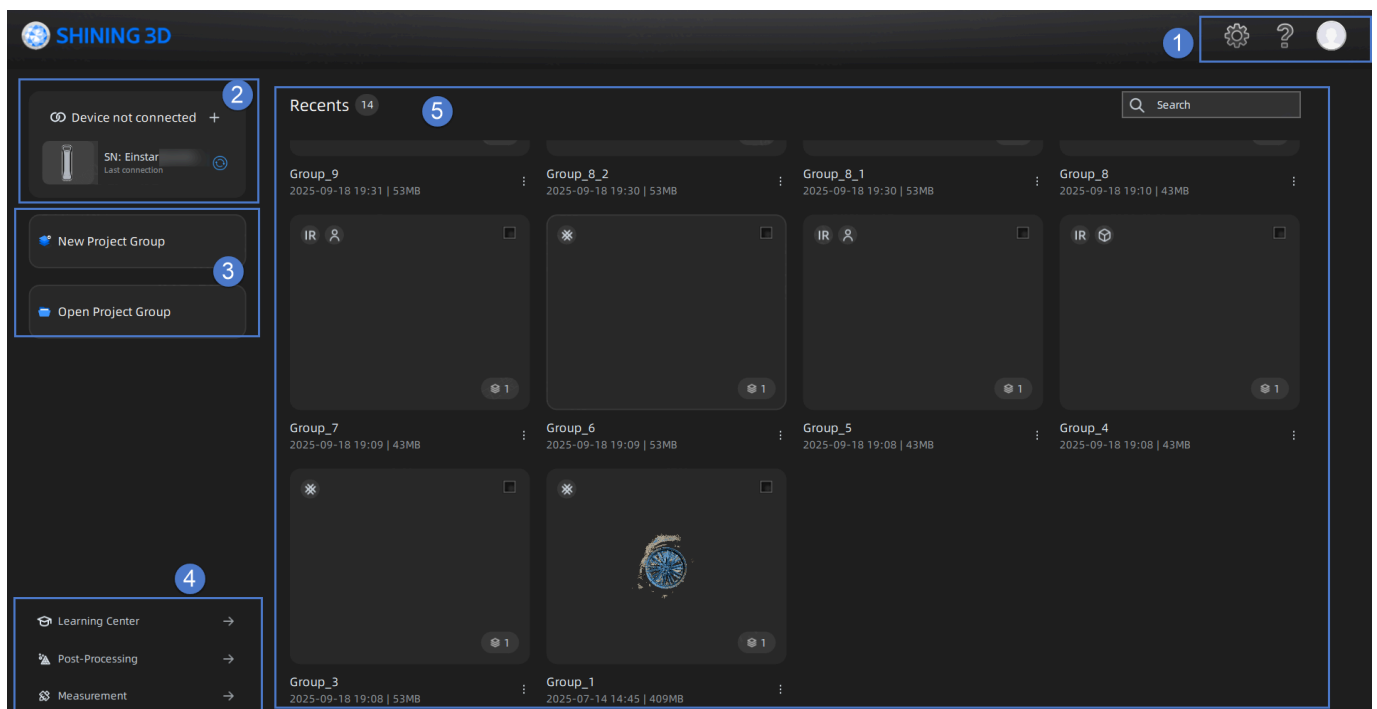

① Settings and Help







- Select Language: Choose the language for software.
- Compatible with 3Dconnexion SpaceMouse: When enabled, you can quickly rotate, pan, zoom, and perform other shortcut operations on models in a 3D scene with the 3Dconnexion SpaceMouse. See [3Dconnexion SpaceMouse](#) for more details.
- Device Prompt Tone: After enabling, you can adjust the volume of the device's button sounds and alerts.
- Factory Default: Click **Recover** to initialize all settings and the software will restart automatically.



-  About: You can view the device name, serial number, calibration board, software version and other information. After checking **Download Updates Automatically**, it will detect the update and prompt you to

install.

-  System Diagnose: Check whether your computer configuration meets the running requirements. If  appears, it means that the configuration meets the requirements. If  appears, it means that there are some issues that should be resolved. Click **Refresh** to diagnose again.
-  Support: Access the user manual, our contact information, and beginner tutorials; support for remote assistance (Teamviewer) and log export.

 **Note**

If the software displays a pop-up stating "No TeamViewer detected" when you use remote assistance function, click **Select Path** in the dialog box and choose TeamViewer's .exe file to update the launch path for TeamViewer.



If you have not logged in to the passport, you can click here to log in; if you have already logged in, you can perform the following operations.

- Reverse Engineering Service: By sending us the scanned project files and specific information, you can get our assistance in reverse engineering.
- Account: You can view login status, account information, and authorization period.
- Login: You can log in / log out of your account.
- My SHINING 3D Account: Click to enter the personal center.
- Official Website: Click to visit our [official website](#) ² for more products and information.
- Facebook: Enter our Facebook to view product introduction and learn other operations.
- Shining 3D Digital Cloud: Upload your model to SHINING 3D Cloud.

② Device Information

If the device is successfully connected, the name, serial number, power and storage space of the connected device will be displayed here; if the device is not connected, please connect the device wirelessly or wired.

Connected

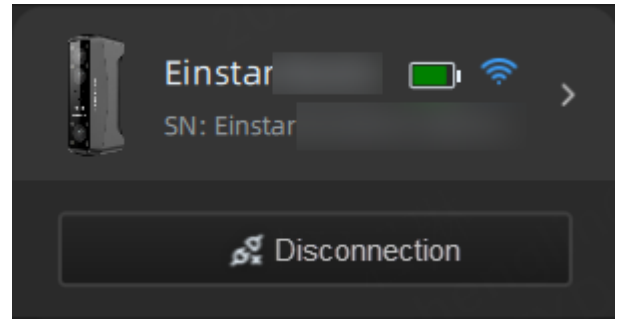
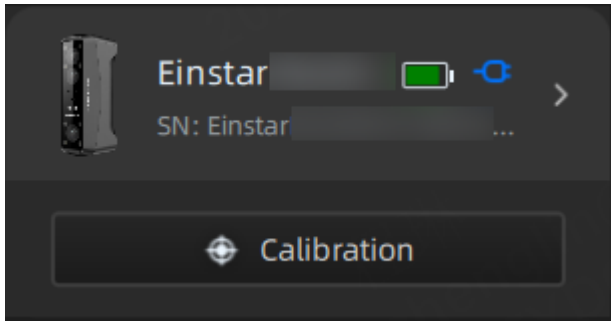

Icon	Description	Icon	Description
	Displays the current battery level.		The current device is connected via cable.
	The current device is connected wirelessly.		Clicking will disconnect the device while in the wireless connection state.
 Calibration	Clicking will quickly jump to the calibration interface while in a wired connection state.		

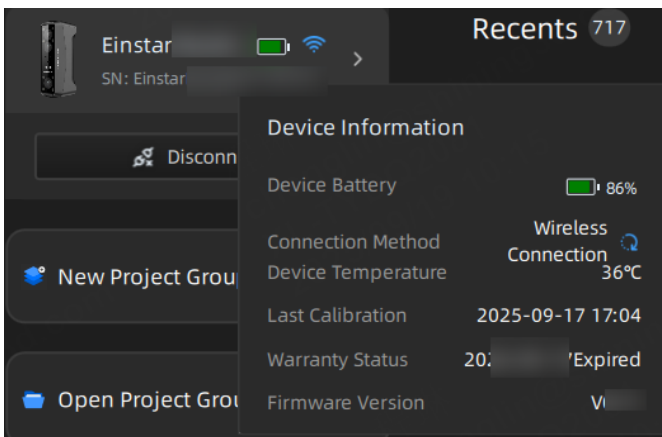

Once the device is successfully connected, the information about the device will be displayed in the top left corner; click > to view more detailed device information.

Note

In a wireless connection state, if the signal is poor, you can click on to optimize the network.

Not Connected

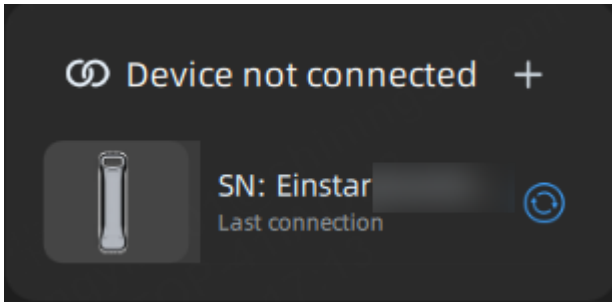

Click + to view the wireless and wired connection instructions; for specific operation instructions, please see [Connection](#).

Note

If the scanner is disconnected, click  to reconnect the scanner immediately, or wait for the scanner to reconnect automatically.

③ Project Group

Click here to quickly create or open a project group.



New Project Group

1. Click **New Project Group**.
2. In the prompt window, name the project group and click **Browse** to select the save path.
3. Click **Confirm** and all scanned data will be saved to the folder with the name you just set.

Open Project Group

1. Click **Open Project Group**.
2. Select **Open Local File** or **Open Device File**.
3. In the prompt window, select the project group.
4. Click **Open** to import the project group into the software.

④ Quick Links

- Click **Learning Center**  to quickly view our company's contact information and equipment teaching materials.
- Click  **Post-Processing** → or  **Measurement** → to quickly jump to the corresponding interface for related operations.

⑤ Project Group List

Recently opened or newly created project group files with relevant information (name, operation time, and file size) are displayed here.

Function	Description
	Enter the name to quickly find the project or project group.
Delete	This button will appear after selecting a project or project group. Click this button to delete the selected project or project group. Once deleted, it cannot be restored.

Upgrade

When new functions are released, bugs are fixed, or software performance is optimized, a new version will be available. We recommend upgrading promptly to enhance your scanning experience.



Firmware Upgrade

After launching the software, if a firmware upgrade pop-up appears, proceed with the firmware upgrade.

Note

- To perform a firmware upgrade, the battery level needs to be $\geq 30\%$.
- Firmware upgrades are only supported when connected via the cable.

Software Upgrade

If you check **Automatically download new versions** in  > **About**, the software will notify you via a pop-up when a new version is detected at startup. If unchecked, you can still manually check for updates and view the current version in  > **About**.

Once a new version is detected, click **Download Now** to let the software download the installer in the background while you continue using it.

After the download completes, click **Install Now** to begin installing the new version.

Caution

- If you close the software during download, you can choose to resume the download in the background.
- The software will close during installation, so ensure your scanned data is saved beforehand to avoid loss.

Device Connection

Supports both wireless and wired connections for devices; the device can be used for scanning after the connection.

Wireless Connection

1. Open the battery compartment as shown in the illustration and insert the battery.

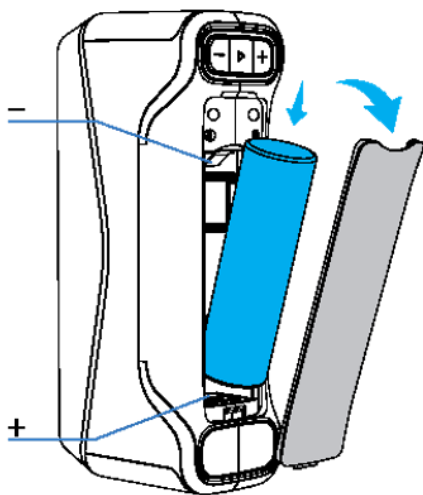

Note

Place the battery correctly according to the positive and negative directions shown in the illustration.

2. Long press the  button on the device body to power it on. The status indicator light flashing blue means it is powered on.

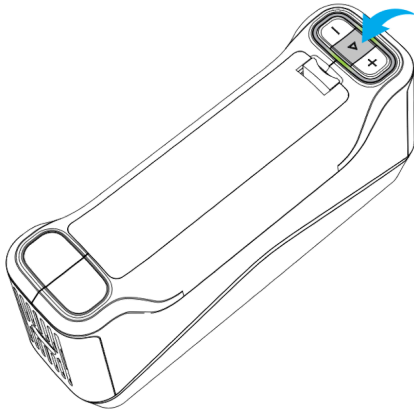

3. Launch the **EXStar Hub** software.
4. Click **+** in the upper left corner of the software homepage to open the device connection window.
5. In the device connection window, select the current device's hotspot to connect.

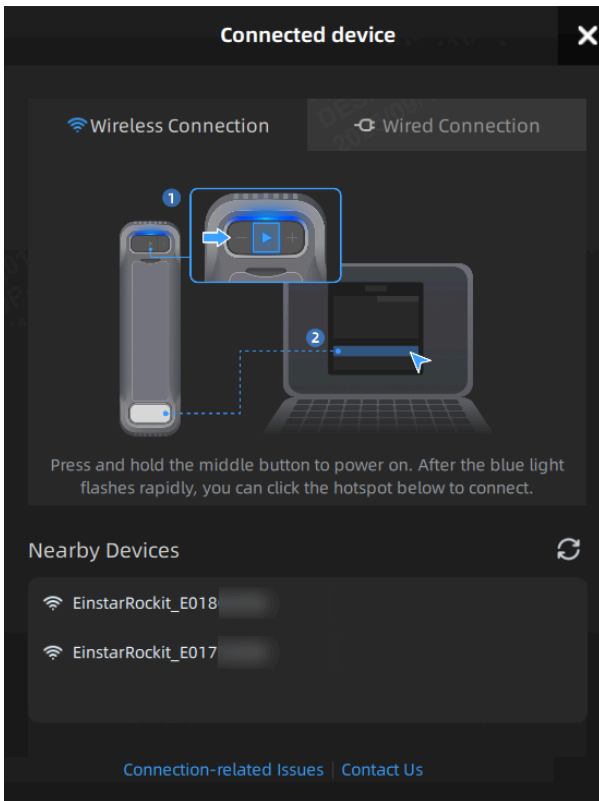

 **Note**

The hotspot name is EinstarRockit_xxx, and the password is fixed as EinstarRockit.

6. Once you connect, the status indicator light changes to a steady green, and the upper left corner of the software homepage shows the device information. The scanner is now ready for scanning.

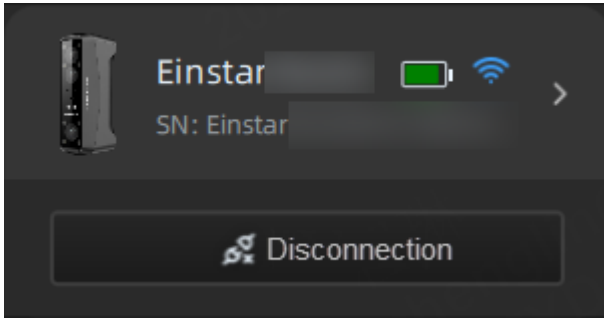

Wired Connection

1. Long press the  button on the device body to power it on. The status indicator light flashing blue means it is powered on.

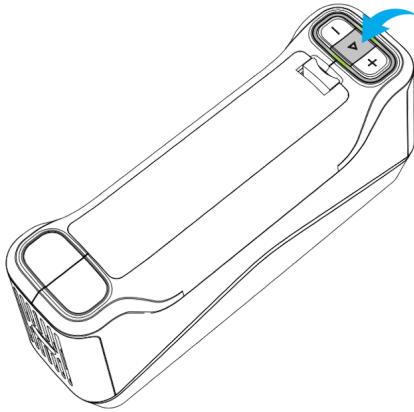

2. Launch the **EXStar Hub** software.
3. Use the provided Type-C cable to connect the scanner to the computer.



4. When the software recognizes the scanner, it will automatically connect to it.

- Once connected, the status indicator light will change to a steady green, and the upper left corner of the software homepage will display the relevant information of the device. At this point, the scanner can be used for calibration and scanning.

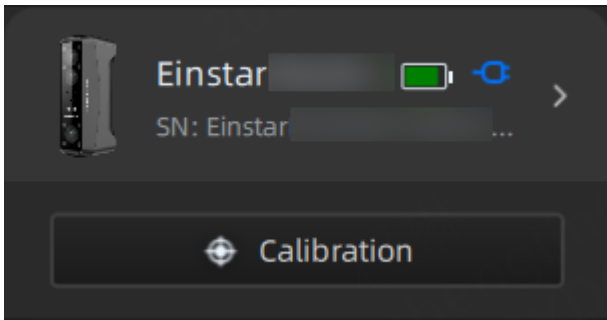

Note

If the scanner has been connected to the computer beforehand, unplug and reinsert the Type-C cable after launching the software.

Disconnection

In wireless connection state, click **Disconnect** on the software homepage. In wired connection state, simply unplug the Type-C cable from the device.

Note

Only one device can be connected at a time. Disconnect the connected device before switching to a different one.

3Dconnexion SpaceMouse

This software is compatible with 3Dconnexion SpaceMouse. With the 3Dconnexion SpaceMouse, you can rotate, pan, zoom, and perform other shortcut operations on models in a 3D scene.

For more operations, please refer to the [3Dconnexion user manual](#).









Connection



Steps

1. Take out the 3Dconnexion SpaceMouse from its packaging and insert the connecting cable into a USB port on your computer.
2. Open the [official website](#) [↗] to download the software.
3. Download and install the latest version of the 3Dconnexion software.
4. Run the software and click  **Trainer** for a quick guide.

Interface

Icon	Description
	Learn how to quickly use the 3Dconnexion SpaceMouse.
	Find the manuals for all 3Dconnexion products.
	Open the settings panel to customize your 3Dconnexion devices.
	Use the 3Dconnexion Viewer to review 3D models. Supported formats: .stp, .step, .igs, .iges, .obj, .stl, .ply, .jt, .glTF.
	Create high-resolution picture collages with SpaceMouse by 3Dconnexion Collage.
	Test and practice your skills by assembling the landing gear of an aircraft.
	Register your product after the installation to benefit from 3Dconnexion services.
	Find instructive videos for your 3Dconnexion devices.
	Provide feedback to the 3Dconnexion product team.

Buttons

Panel



Color Display

3Dconnexion Keys

CustomView Buttons

Control Cap

Rotation Toggle Button

Keyboard Modifiers

QuickView Buttons









Menu Button

Fit Button

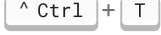

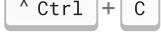
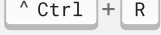
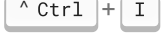

Button	Description
Color Display	It provides visual feedback on the assigned commands. You have the option to adapt the display brightness, switch between text or icons, and change the text size on the LCD in the 3Dconnexion Settings.
3Dconnexion Keys	The SpaceMouse Enterprise features twelve additional programmable function buttons. You can personalize commands assigned to the function buttons using the 3Dconnexion Settings.
CustomView Buttons	Above the QuickView Buttons, the SpaceMouse Enterprise also has 3 CustomView Buttons that allow you to store and retrieve your own views. To save a specific view, press and hold one of the CustomView Buttons until the message 3Dconnexion View saved appears on your screen. If you want to return to your saved view, just press the button once.
Control Cap	The Controller Cap is the heart of your SpaceMouse Enterprise. Its Six-Degrees-of-Freedom (6DoF) sensor allows you to push, pull, rotate, or tilt to pan, zoom and rotate your drawings and 3D models
Rotation Toggle Button	In the center between the QuickView Buttons is the Rotation Toggle Button. Pressing it once locks the rotation around all axes. The status LED will light up to indicate that rotation toggle is now active.
Keyboard Modifiers	The SpaceMouse Enterprise comes with eight Keyboard Modifiers that work like the corresponding keys on your keyboard. You can personalize the commands assigned to the Keyboard Modifiers using the 3Dconnexion Settings.
QuickView Buttons	The SpaceMouse Enterprise features five QuickView Buttons helping you to quickly bring your drawing or 3D model into the desired view. The buttons have a secondary assignment (blue font) that you can call up by a long press. You can program both the first assignment and the second assignment of the buttons in the 3Dconnexion Settings.

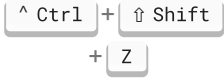
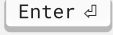
Button	Description
Menu Button	The Menu Button allows for fast and easy customization of your 3Dconnexion devices. Pressing it will take you directly to the 3Dconnexion Settings. Select the device you want to configure in the flyout window and customize it.
Fit Button	With the Fit Button, you will never lose sight of your drawing or 3D model. Press it to bring your drawing back to the center of your screen.

3Dconnexion Keys

No.	Keyboard Shortcut	Function
1		Toggle functions between Point Cloud Edit and Edit Markers (only works in Scan).
2		Toggle functions between select visible and select through (only works in Post-Processing).
3		To toggle the method of selecting data. For more, please see Data Editing .
4		Select all
5		Unselect
6		Connected domain
7		Invert
8		Delete selected data
9		Undo
10		Redo
11		Cancel edit
12		Apply edit

Control Cap

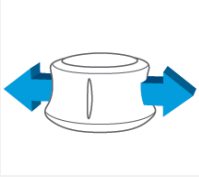
Figure	Description
	Tilt cap left/right to rotate the model on its Z axis.
	Rotate the model on its Y axis.
	Tilt cap forwards/backwards to tumble the model on its X axis.
	Zoom the model in and out.
	Move the model up and down.
	Move the model left and right.

Calibration



Notice

With calibration, the scanner parameters are recalculated, which not only ensures the accuracy of the scanner, but also improves the scan quality.

Please calibrate the scanner before scanning in these situations:

- Using the scanner for the first time.
- The scanner has not been used for a period of time (1 to 2 weeks).
- The scanner has experienced significant shaking or vibration.
- The scanned data is incomplete, and the data quality has severely declined.
- There is a significant drop in accuracy during scanning, with frequent alignment errors or loss of tracking prompts.

 **Note**

If the scanner has not been calibrated for more than 7 days,  **Recalibrate** will appear in the status bar at the top of the screen; if it has not been calibrated for more than 14 days,  **Recalibrate** will appear.

 **Caution**

- Please store the calibration tools properly after use.
- Calibration tools are for calibration purposes only and should not be used for anything else.
- Do not place heavy objects or sundries on the calibration tools.
- Keep the calibration tools away from corrosive solutions, metals, and sharp objects.
- Ensure that the markers on the calibration tools are undamaged and clean, and that the front of the calibration board is free of scratches.
- Use calibration board that matches the scanner to avoid issues such as low calibration accuracy or calibration failure due to mismatched boards.
- Do not use any chemical liquids to clean the calibration tools; if cleaning is necessary, gently wipe the tools with a clean, moist cloth.

Operation

The entire calibration process includes **camera calibration** and **white balance calibration**. You can complete the corresponding calibration according to your needs.



Note

Calibration is only supported in wired mode.

Binding the Calibration Board



Before the first calibration or after changing the calibration board, please bind the calibration board first, then start the calibration.

Method 1:

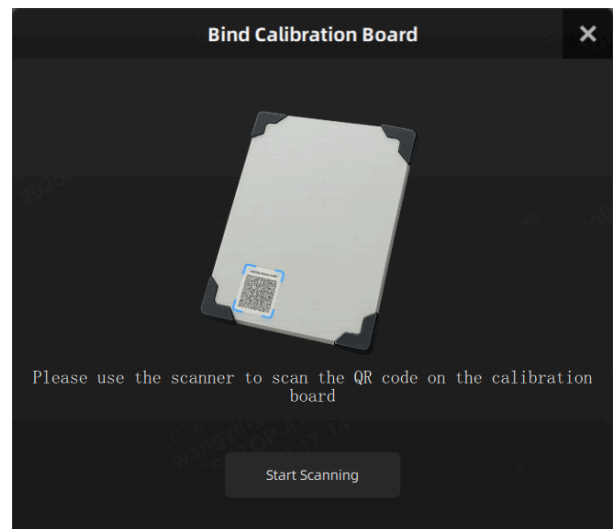

1. After connecting the device, click  **Calibration** in the navigation bar at the top of the interface to switch to the calibration interface.
2. Click  in the lower right corner of the interface to open the binding calibration board window.
3. Click **Start Scanning**.
4. According to the illustration, use the device to scan the QR code on the calibration board to complete the binding.



Note



- If this is your first calibration, the binding calibration board window will automatically pop up after switching to the calibration interface. You can use the device to scan the QR code on the calibration board to complete the binding as shown.
- If the light is too dim, click  or press  on the device to turn on the device's fill light before scanning the QR code.

Method 2:

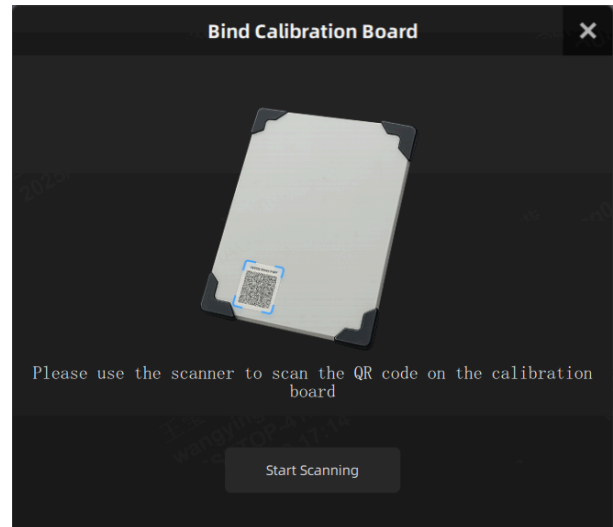
1. Click  >  **About** > **Calibration Board No.**  to open the binding calibration board window.
2. Click **Start Scanning**.
3. According to the illustration in the binding calibration board window, use the device to scan the QR code on the calibration board to complete the binding.





Note

If the light is too dim, click  or press  on the device to turn on the device's fill light before scanning the QR code.

Camera Calibration

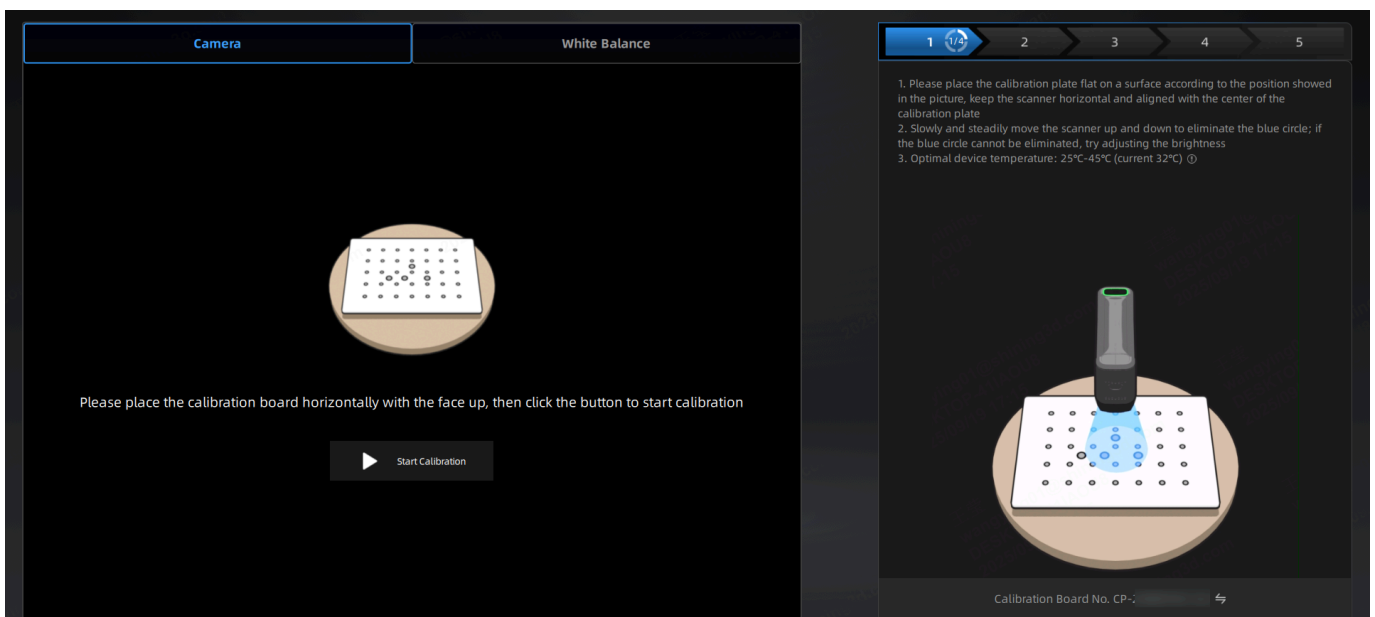
A calibration process requires completing the calibration at all angles and distances according to the illustrations.



 **Caution**

- Do not perform calibration on reflective tile floors.
- Do not perform calibration in environments with cluttered markers.

1. Place the calibration board on the flat surface with the marked side facing up.
2. Align the red crosshair of the scanner with the white crosshair on the calibration board; when the two crosshairs overlap, the crosshair will turn green.
3. Move the scanner vertically up and down until the blue area on the screen is completely eliminated.

 **Caution**

- When moving the scanner up and down, please ensure:
 - The center of the scanner remains aligned with the center of the calibration board.
 - The scanner remains parallel to the plane where the calibration board is located.
- If you are unable to eliminate the blue area completely while moving the scanner up and down, try adjusting the camera brightness using the brightness slider on the left side.

4. Place the calibration board on the holder as shown.
5. Repeat steps 2 to 3 to complete the calibration for that direction.
6. Rotate the calibration board as shown, and repeat steps 2 to 3 to complete the calibration for other directions.
7. After completing calibration for all directions, a calibration file will be automatically generated.
8. Exit calibration and proceed to scanning after calibration, or recalibrate if the calibration fails.

 **Note**

- After calibration is complete, please store the calibration board properly for future use.
- If calibration fails multiple times, please promptly [contact technical support](#) and provide the error code.

White Balance Calibration

White balance calibration is an optional calibration step. It can be performed when there is a discrepancy between the scanned texture data and the actual texture of the object.

Steps

1. Please place the calibration board with the white side facing up on a flat surface.
2. Aim the scanner at the calibration board.

3. Move the scanner vertically up and down until the white circle on the screen completely overlaps with the blue circle.
4. After successful calibration, you can exit calibration and proceed to scanning; if calibration fails, please recalibrate.

Note

- After calibration is complete, please store the calibration board properly for future use.
- If calibration fails multiple times, please promptly [contact technical support](#) and provide the error code.

Scan Modes

The software supports two scan modes: **Laser Scan** and **IR Scan**.

Laser Scan

Laser Scan refers to a method that uses laser lines projected by the scanner to scan objects, typically employed for high-precision industrial inspection scans. It supports two types of scanning light sources: cross-line and parallel-line.

IR Scan

IR Scan is a method to scan people and objects without using laser lines. Before starting the scan, [project group settings](#) need to be configured.

Scan

Project Group

Project group is the standard file structure of the software. It contains one project or more. Each project contains the data of its own. You need to create or open a **Project Group** before scanning.



Create a Project Group

Two ways to create a project group:

Method One: Click **New project group** in the [home screen](#) interface.

Note

If you select **IR Scan**, set parameters such as scan mode and alignment mode when creating a new project group; for details, please see the [Project Group Settings](#).

Method Two: Click  and select **New project group** in the scanning interface.

 **Note**

The project group created through **method two** is consistent with the scanning mode of the current interface's project group, and it is not possible to select **Laser** or **IR** scan modes.

In the prompt window, name the project group and click **Browse** to select the save path; then click **Confirm** and all scanned data will be saved to the folder with the name you just set.



Open a Project Group

You can open a project group and perform re-scanning or editing on the scanned data.

Method One: Click **Open project group** on the [home screen](#) interface.

Method Two: Click  and select **Open project group** in the scanning interface.

In the prompt window, select the project group file and then click **Open**.

 **Note**

- The current project group will be saved automatically when opening a project group.
- To rescan the imported project, use the same device that scanned the imported project.

Project Group Settings

In IR Scan mode, after [creating a new project group](#), you need to set it up; different scan modes need different settings, including alignment mode, resolution, and texture.

Portrait Scan

Select alignment mode

Align Mode	Description
Feature Alignment	Automatically completes alignment using the geometric features of the scanned object's surface.
Texture Alignment	Automatically completes alignment using the surface texture of the scanned object.

 **Note**

Alignment mode supports multi-selection.

Select resolution

You can adjust the resolution by dragging the slider or by clicking **High**, **Medium**, or **Low** for quick selection.

Level	Point Distance
High	0.2 mm
Medium	1.0 mm
Low	2.0 mm

 **Note**

With smaller values, you will get more details through scanning, but it will lead to a larger file size and a longer processing time.

Texture Scan

You can enable or disable texture scan.

 **Note**

- **Texture Scan** cannot be adjusted again after creating the project group.
- This function is automatically enabled and cannot be turned off in **Texture Alignment** mode.

Object Scan

Object size

Object Size	Description
Medium and large object	Object size larger than 200 mm X 200 mm X 200 mm
Small object	Object size between 50 mm X 50 mm X 50 mm and 200 mm X 200 mm X 200 mm

Select alignment mode

Align Mode	Description
Hybrid Alignment	Support selecting one or more alignment modes among features, markers, and textures. If the object to be scanned has rich and varied geometric features and texture features, it is recommended to select feature or texture stitching mode.
Global Markers	Completes alignment using markers, suitable for objects lacking rich and variable geometric features and requiring high accuracy.

Note

- In **Texture Alignment** mode, the frame rate is lower, which may affect scanning smoothness; it is recommended that you check this option only when necessary.
- When the device battery is below 30%, the **Markers Alignment** mode and **Global Markers** mode are not supported.

Select resolution

You can adjust the resolution by dragging the slider or by clicking **High**, **Medium**, or **Low** for quick selection.

Level	Point Distance
High	Medium and large object: 0.5 mm. Small object: 0.2 mm.
Medium	Medium and large object: 1.0 mm. Small object: 0.3 mm.
Low	Medium and large object: 2.0 mm. Small object: 0.5 mm.

Note

- With smaller values, you will get more details through scanning, but it will lead to a larger file size and a longer processing time.
- Resolution cannot be changed once the project group has been created.

Texture Scan

You can enable or disable texture scan.





 **Note**

- **Texture Scan** cannot be adjusted again after creating the project group.
- This function is automatically enabled and cannot be turned off in **Texture Alignment** mode.

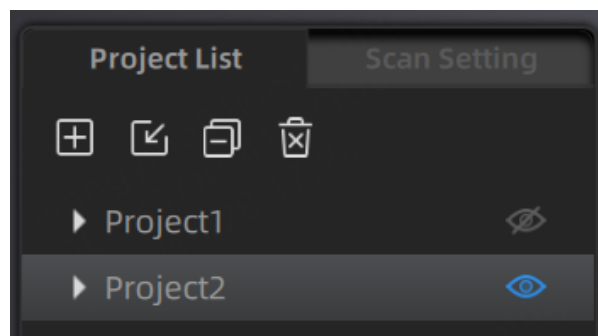
Project Management

After connecting the scanner and entering the scanning interface, you can manage the projects in the currently created or opened project group. Each project is a part of the project group. You can use these buttons to manage projects.



Function	Description	Note
 New Project	Click this button to create a new project when the scanner is connected.	In Laser Mode , if the project group contains a project scanned with Feature Alignment , you cannot select other alignment modes (Markers Alignment or Global Markers Alignment) for the new project.
 Open Project	Click this button to import a project.	<ul style="list-style-type: none"> • It is not supported to open projects with different resolutions in the same project group. • It is not supported to open projects scanned by different devices in the same project group. • In IR Scan, it is not supported to open projects with different scanning objects settings (scan people / scan objects) in the same project group. • In Laser Scan, it is not supported to open projects with Feature Alignment and other alignment modes in the same project group.
 Remove Project	Click this button to remove the project from the project list.	The project remains in the folder and can be imported back to the list.
 Delete Project	Click this button to delete the project.	This operation will delete the selected project and its data at the same time.
 Visible / Invisible	Click this button to show or hide the data or markers.	/

Note

- If the project being deleted or removed is the last project in the list (i.e., the current project), the previous project in the list becomes the current project, and you can perform scanning operations on it.
- If a project with the same name as an existing project in the list is opened from a different path, "_1" will be appended to the name of the opened project.
- If a project is imported into the project group from a different path, deleting it will not affect the original data in the original path. Only the project data copied to the project group folder will be deleted.

Scan Preparation

Before scanning, please refer to the following scanning requirements and make the necessary preparations to enhance your scanning experience.

Markers Placement

When scanning using **Markers Alignment** or **Global Markers**, markers need to be placed on the object to be scanned in advance.

Please note the following requirements for placing markers:

- Place markers evenly and randomly.
- Do not use damaged or incomplete markers.
- Do not place markers on surfaces with high curvature.
- Do not use dirty or contaminated markers.
- Place small markers on edges of models or small areas.



Markers are attached correctly

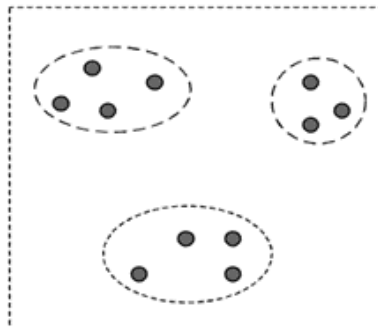

Wrong: Artificial grouping of markers

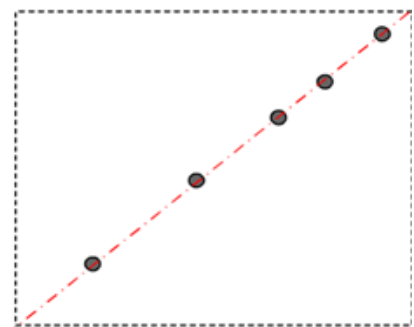

Wrong: Attach markers only in one line

Portraits

Please note the following requirements for scanning portraits:

- Hairstyle: Keep hairstyles neat and avoid loose strands or bangs; comb hair before scanning.
- Clothing: Avoid wearing reflective clothing; do not wear accessories or glasses that may cause reflections.
- Posture: Since the person should remain as still as possible during the scanning process, choose a comfortable and easy-to-maintain posture before scanning.

 **Note**

For portrait scanning, please scan the face first and try to complete it in one go to avoid alignment errors caused by muscle movement or blinking.

Objects

Please note the following requirements for scanning objects:

- For scanning transparent, shiny, or reflective objects (especially those with black reflective surfaces), use washable or vanishing scanning spray.
- For objects lacking surface features or with repetitive features:
 - Place markers on the object's surface and select **Markers Alignment** mode for scanning.
 - Randomly add rich geometric features on or around the object's surface and select **Feature Alignment** mode for scanning.
 - Use an erasable marker to enhance surface features by drawing on the object's surface and selecting **Texture Alignment** mode for scanning.

 **Note**

Types of objects unsuitable for scanning:

- Soft material object that cannot be hung.
- Lattice structures with many small deep holes.
- Moving or shaking objects. Frequent coordinate changes will lead to a poor scanning quality.

Scan Interface

After entering the scanning interface, you can adjust settings and perform scanning operations.

Overview

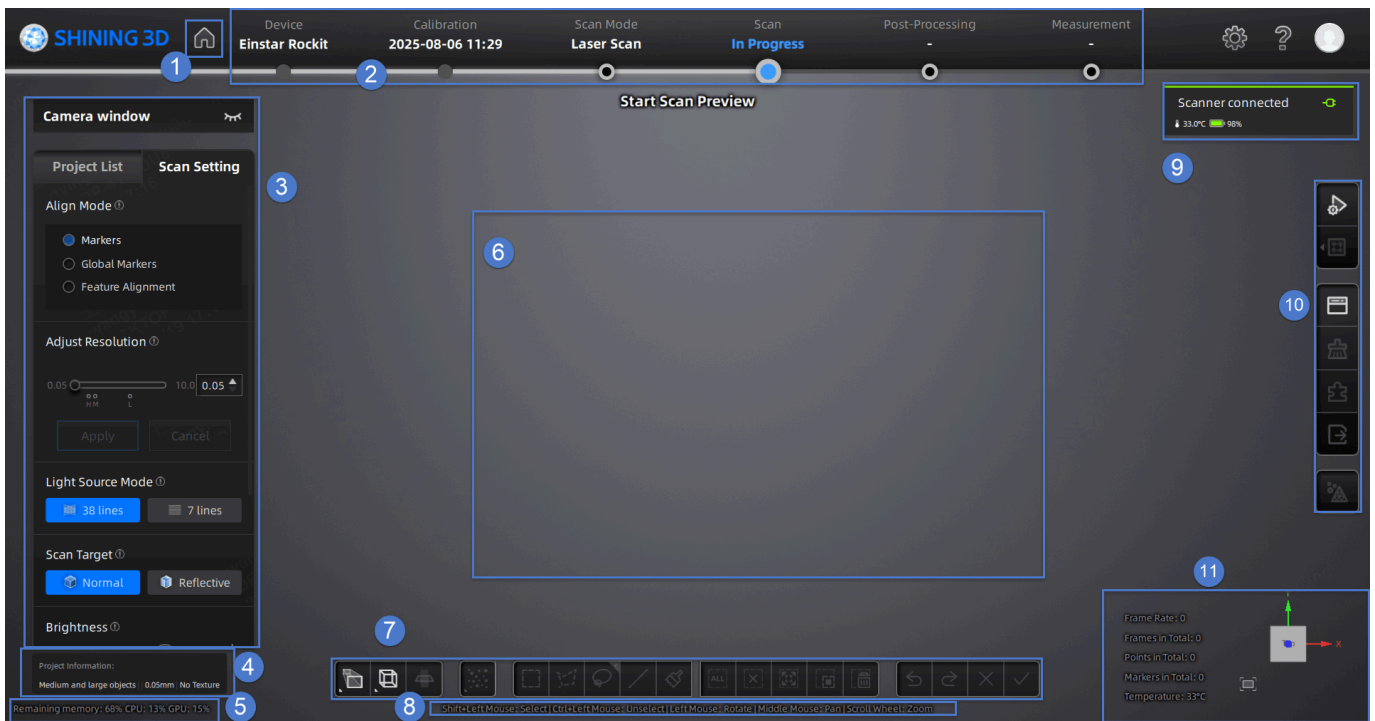





Note

The screenshot shown above is for illustrative purposes only. Always refer to the actual software interface.

① Home Screen

Click  to quickly return to the home screen.

② Navigation Bar

- Device: When the device is online, the device name is displayed. When the device is offline, click  on the navigation bar to reconnect the device.
- Scan Mode: Click  on the corresponding position in the navigation bar to choose the [scan mode](#).
- Scan: Click  on the corresponding position in the navigation bar to start the [scanning](#).
- Post-Processing: After scanning, click  to switch to the **Post-Processing** interface where you can do [mesh](#) and [mesh editing](#) for the data. Measurement: Click  on the corresponding position in the navigation bar to switch to **Measurement** interface where you can [measure](#) your model here.

③ Scanning Settings

- Camera Windows: To preview the actual scene during scanning. Parameters can be adjusted accurately through the camera window.
- Project List: To create, open, or delete projects. For more, see [Project Management](#).
- Scan Setting: To set scanning parameters. For more, see [Settings](#).

④ Project Group Information

To display the detailed information such as the scan mode and resolution of the current project group.

⑤ Memory / CPU / GPU

- Remaining Memory: To display the percentage of remaining memory.
- CPU Usage: To display the CPU usage of the computer in real time. You may need to close other unrelated software if it is too high.
- GPU Usage: To display the GPU usage of the computer in real time.

⑥ Preview / Scanning Window

To preview the model and check the scanned model.

⑦ Editing Toolbar

To edit data after scanning. See more details in [Data Editing](#).

⑧ Shortcuts

To change the perspectives and move the model by the composition of keys.

⑨ Connection Information

Displays the current device's connection status, battery level, and temperature.

Note



In case of poor signal under wireless connection, click  to optimize the network.

⑩ Right Sidebar

For more, see [Scanning](#).

⑪ Other Information

To show information about FPS, Frames in Total, Points in Total, etc.

Function	Description
 <p>Zoom to Fit</p>	<p>Click  to center the model and adjust the view size to fit the screen automatically.</p>
 <p>View Controller</p>	<ul style="list-style-type: none"> • When adjusting the model, a coordinate system reference is provided. • You can quickly adjust the model view by clicking on different faces of the view controller.

Settings

You can adjust the scanning settings for the current project in the scan interface.

Laser Scan

Align Mode

Align Mode	Description	Supported Marker Size
Markers Alignment	Completes alignment using markers, suitable for objects with distinct geometric features, flat areas with minimal geometric features, and scenes requiring accuracy.	<ul style="list-style-type: none"> • 3 mm • 6 mm • 12 mm
Global Markers	Completes alignment using markers, suitable for objects lacking rich and variable geometric features and requiring high accuracy.	<ul style="list-style-type: none"> • 3 mm • 6 mm • 12 mm
Feature Alignment	Automatically completes alignment using the geometric features of the scanned object's surface, suitable for objects with rich geometric features or those that cannot have markers pasted.	/

Note

- **Acquire Texture** cannot be enabled in **Feature Alignment** mode.
- Please make sure the remaining battery of the scanner is more than 25% when scanning with **Feature Alignment**.

Resolution

You can adjust the resolution in real-time by dragging the slider or fill in the value before scanning or after pausing the scan.



Note

- If a project group contains more than one project, this function is not available for the second or later projects.
- It is recommended that you enable the data quality indicator and rescan the areas with lower quality (yellow areas) after changing the resolution.

Light Source Mode

Light Source Mode	Description
38 Lines	This mode is suitable for rapid scanning.
7 Lines	This mode is suitable for detailed scanning.

Scan Target

It supports scanning of both normal objects and reflective objects. When scanning reflective objects, select **Reflective** to improve the scanning effect.

Brightness

The red dots in the camera window indicate overexposed areas. To improve scanning quality, it is recommended that you lower the camera brightness when there are large overexposed areas, or increase the camera brightness when the camera window is too dark.



Note

When scanning textures, if the light is too dim, click  on the texture camera window to turn on the texture fill light.

Acquire Texture

Once enabled, real-time texture mapping can be applied to the scanned data.

Data Quality Indicator

When enabled, it will differentiate scan quality in colors: blue represents high-quality scanned data and yellow represents insufficient scanned data that requires further scanning.

 **Note**

This function is unavailable when scanning global markers.

Outdoor Mode

To scan normally in the glare environment such as outdoors.

 **Caution**

Please avoid direct sunlight when scanning.

Local Enlarged View

When the function is enabled, the scanning interface only displays the local perspective of the scanned object, which can be used for supplementary scanning of small holes.

 **Note**

When the resolution is less than 0.2 mm, it is recommended that you enable this function.

View Lock

When the function is enabled, the view will be locked during scanning and not follow the scanning path, which can be used for scanning data from the locked view.

IR Scan





- **Camera Window**

Preview the actual scene during scanning. Parameters can be adjusted accurately through the camera window.

- **Brightness**

The red dots in the camera window indicate overexposed areas. To improve scanning quality, it is recommended that you lower down the camera brightness when there are large overexposed areas, or increase the camera brightness when the camera window is too dark.

 **Note**

- Click  to enable auto exposure so the scanner can adjust the brightness automatically according to the actual situation.
- When scanning textures, if the light is too dim, click  on the texture camera window to turn on the texture fill light.

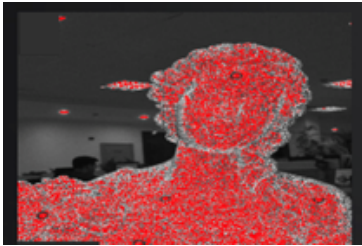

Brightness is too high

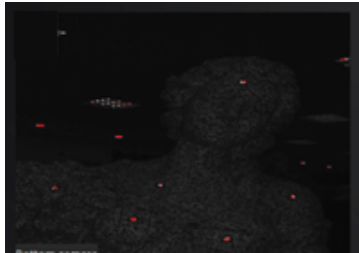

Brightness is too low

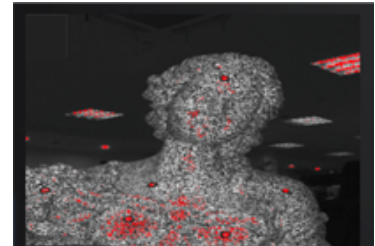

Brightness is proper

- **Working Distance Adjustment**

Drag the slider to adjust the working distance and the scanner scans only within the set distance. This function can effectively filter out unnecessary noise data.

- **Plane Detection**

When enabled, it can reduce the possibility of misalignment.

 **Note**

- If you need to scan flat or featureless objects, it is recommended that you place markers to assist with alignment.
- If this function does not work well, you can try using **Auto Cutting Plane**.

- **Data Quality Indicator**

When enabled, it will differentiate scan quality in colors: blue represents high-quality scanned data and yellow represents insufficient scanned data that requires further scanning.

 **Note**

Show the color only before generating the point clouds.

- **Auto Cutting Plane**

When enabled, it will automatically identify the base plane and mask the scanned data below it during scanning; you can effectively filter out unnecessary noise data through this function, improving data processing efficiency.

 **Note**

The marked plane during the scanning preview process can change in real-time and the last marked plane at the end of the scanning preview will be the final plane.

- **Adjust Resolution**

You can adjust the resolution in real-time by dragging the slider or fill in the value before scanning and after pausing the scan.

 **Note**

- If a project group contains more than one project, this function is not available for the second or later projects.
- It is recommended that you enable the data quality indicator and rescan the areas with lower quality (yellow areas) after changing the resolution.



Object

- **Camera Window**

Preview the actual scene during scanning. Parameters can be adjusted accurately through the camera window.

- **Scan Mode**

In **Global Markers** mode, scan the global markers first before scanning the point cloud.

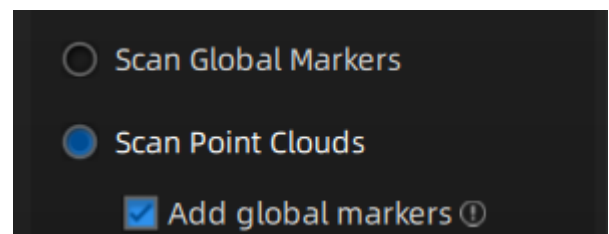



 **Note**

- Click  **Open global markers file** to import global markers files.
- The **Add global markers** cannot be ticked during the scanning.
- If the **Add global markers** is ticked before scanning the point clouds, new markers recognized during the scanning process will be added, but the newly added markers will not be saved to the opened global markers file.

- **Brightness**

The red dots in the camera window indicate overexposed areas. To improve scanning quality, it is recommended that you lower down the camera brightness when there are large overexposed areas, or increase the camera brightness when the camera window is too dark.

 **Note**

- Click  to enable the auto exposure and the scanner can adjust the brightness automatically according to the actual situation.
- When scanning textures, if the light is too dim, click  on the texture camera window to turn on the texture fill light.

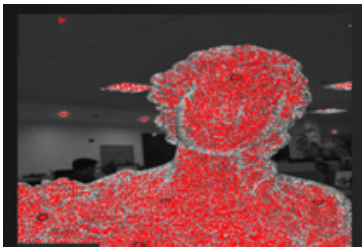

Brightness is too high

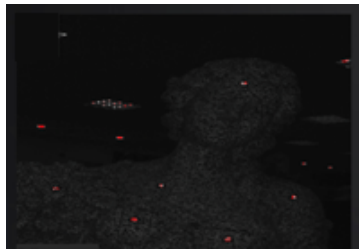

Brightness is too low

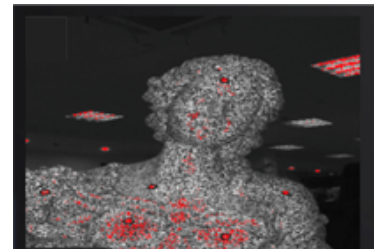

Brightness is proper

- **Working Distance Adjustment**

Drag the slider to adjust the working distance and the scanner scans only within the set distance. This function can effectively filter out unnecessary noise data.

- **Data Quality Indicator**

When enabled, it will differentiate scan quality in colors: blue represents high-quality scanned data and yellow represents insufficient scanned data that requires further scanning.

 **Note**

Show the color only before generating the point clouds.

- **Auto Cutting Plane**

When enabled, it will automatically identify the base plane and mask the scanned data below it during scanning; you can effectively filter out unnecessary noise data through this function, improving data processing efficiency.

 **Note**

The marked plane during the scanning preview process can change in real-time and the last marked plane at the end of the scanning preview will be final plane.

• **Adjust Resolution**

You can adjust the resolution in real-time by dragging the slider or fill in the value before scanning and after pausing the scan.

 **Note**

- If a project group contains more than one project, this function is not available for the second or later projects.
- It is recommended that you enable the data quality indicator and rescan the areas with lower quality (yellow areas) after changing the resolution.

Scanning



After adjusting [scanning settings](#), you can proceed with scanning the objects.

 **Note**

The scanned **point clouds** can be directly imported in the **Measurement** interface for creating features, aligning, or measuring.



Switch Scanning Status

You can switch the scanning status by clicking the buttons in the right sidebar.

Function	Description
 Preview	Preview scanning effect and scan parameters can be adjusted according to the scanning effect.
 Start Scan	Start scanning the objects.
 Pause Scan	After starting scanning, click this button to pause scanning.

Generate Point Cloud





After scanning, click  **Optimizing and Generating Point Cloud**, or hover the cursor over the left expand button and click  **Generate Point Cloud** in the expand bar.

Function	Description
 Generate Point Cloud	End scanning and directly generate point cloud; hover the cursor over ◀ to expand the function bar, where you can select Optimizing and Generating Point Cloud .
 Optimizing and Generating Point Cloud	First optimize the point cloud, then generate the overall point cloud. This process takes longer to compute and requires higher memory, but can solve most layering problems caused by cumulative errors, suitable for projects with higher accuracy requirements; hover the cursor over ◀ to expand the function bar, where you can select Generate Point Cloud .

Note

The time it takes to generate point cloud depends on the data size of your project and the hardware configuration of your PC.

Other Functions

Function	Description	Function	Description
 Project Group	Create or open a project group .	 Delete Your Scan	Delete the current scanned data to rescan.
 Align	Align the data as you need.	 Export the Scan	Save the scanned data in the specified format locally.
 Mesh	Mesh your model.		

Data Editing

After pausing [scanning](#), you can use the [editing tools](#) and [right sidebar](#) functions in the scanning interface to edit the data and generate accurate 3D point clouds.





Editing Toolbar



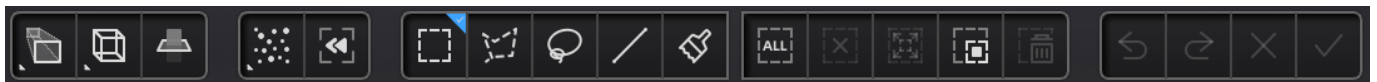



After pausing scanning or generating point clouds, you can use the following tools to edit the data.





Note





After editing the data, you can still click  to perform additional scans.







Function	Description
 Perspective View	The object appears larger when closer, and smaller when farther away, which is consistent with the rule of normal human eyes to observe the 3D world. Click this button again to switch to Orthogonal View .
 Orthogonal View	The object does not appear larger when closer, and smaller when farther away; the size of the object displayed in the view is independent of the current view; Click this button again to switch to Perspective View .
 Multi View	Observe the data from 6 different views.
 Cutting Plane	Create a cutting plane to do a quick cut.

Function	Description
 <p>Point Cloud Edit</p>	<p>In this mode, only point clouds can be chosen. Click it again to switch to Edit Markers.</p> <p> Note Multiple undo or redo operations are supported.</p>
 <p>Edit Markers</p>	<p>In this mode, only markers can be chosen. Click it again to switch to Point Cloud Edit.</p> <p> Note</p> <ul style="list-style-type: none"> • It is necessary to retain at least 4 markers. • Multiple undo or redo operations are supported.
 <p>Rewind</p>	<p>Drag the progress bar to select (highlighted in red) the scanning data corresponding to a specific frame. Clicking Confirm will delete the corresponding data. Clicking Exit will discard the current operation and exit rewind.</p> <p> Note</p> <ul style="list-style-type: none"> • This function is only supported in IR Scan. • If the current data is less than 50 frames, this function is unavailable. • This function is available only for scan data without  global optimization. • Up to 200 frames of data can be rewound once; you can rewind multiple times until the first frame of this scan.

Function	Description
 Rectangular	<p>Select or deselect a rectangular area.</p> <ul style="list-style-type: none"> Use <code>⇧ Shift</code> + <code>left mouse button</code> to select. Use <code>^ Ctrl</code> + <code>left mouse button</code> to deselect.
 Polygon	<p>Select or deselect a polygon area.</p> <ul style="list-style-type: none"> Use <code>⇧ Shift</code> + <code>left mouse button</code> to select. Use <code>^ Ctrl</code> + <code>left mouse button</code> to deselect.
 Lasso	<p>Select or deselect the area by using the lasso tool.</p> <ul style="list-style-type: none"> Use <code>⇧ Shift</code> + <code>left mouse button</code> to select. Use <code>^ Ctrl</code> + <code>left mouse button</code> to deselect.
 Line	<p>Select or deselect the area by using the straight line tool.</p> <ul style="list-style-type: none"> Use <code>⇧ Shift</code> + <code>left mouse button</code> to select. Use <code>^ Ctrl</code> + <code>left mouse button</code> to deselect.
 Brush	<p>Select or deselect the area by using the brush tool.</p> <ul style="list-style-type: none"> Use <code>⇧ Shift</code> + <code>left mouse button</code> to select; use <code>⇧ Shift</code> + <code>mouse wheel</code> to adjust the brush size. Use <code>^ Ctrl</code> + <code>left mouse button</code> to deselect; use <code>^ Ctrl</code> + <code>mouse wheel</code> to adjust the brush size.

Function	Description	Function	Description
 Select All	Select all of the data.	 Unselect	Cancel All selection.
 Connected Domain	Click the button after selecting a patch of data and all connected region to the selected data will be selected.	 Invert	Revert the selection.
 Delete Selected Data	Delete selected data.		





Function	Description	Function	Description
 Undo	The last deletion will be undone. Click multiple times to undo multiple deletion.	 Redo	The last operation will be redone. Click multiple times to redo multiple operations.
 Cancel Edit	Undo all edits.	 Apply Edit	Apply all edits.

Cutting Plane

The cutting plane tool can be used to quickly remove data below the base or multiple planes of an object. You can create and edit cutting planes through the settings panel on the left; after applying the cutting plane, the data below the cutting plane will no longer be collected when scanning again.

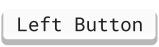
Creation

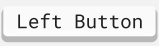
1. On the editing toolbar at the bottom of the interface, click  to enter the cutting plane tool interface.
2. Select the creation method and follow the interface prompts to create the cutting plane.

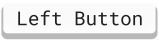
Method	Description
Fitting Point Cloud	Press  +  to select data, and generate the cutting plane according to the selected data.
Creating Straight Line	Press  +  to draw a line, and generate the cutting plane according to the line.
By Markers	Press  +  to select markers. 3 markers or more are required to generate the cutting plane.

3. Click **Create** to create a cutting plane, which will be displayed in the cutting plane list; click **Cancel** to cancel all operations and exit the cutting plane tool interface.

 **Note**

- When saving a global markers file, the cutting plane will be saved together.
- The cutting plane created in the current project are only effective for that project.
- After creating a cutting plane, data below the cutting plane will no longer be collected.
- Cutting planes can be created after opening a global markers file or scanning global markers (before and after optimization).

Editing

- **Delete the selected point cloud data / markers:**
When ticked, the selected point cloud data or markers will be highlighted in red. **Apply** the edit to delete the highlighted point clouds or markers.

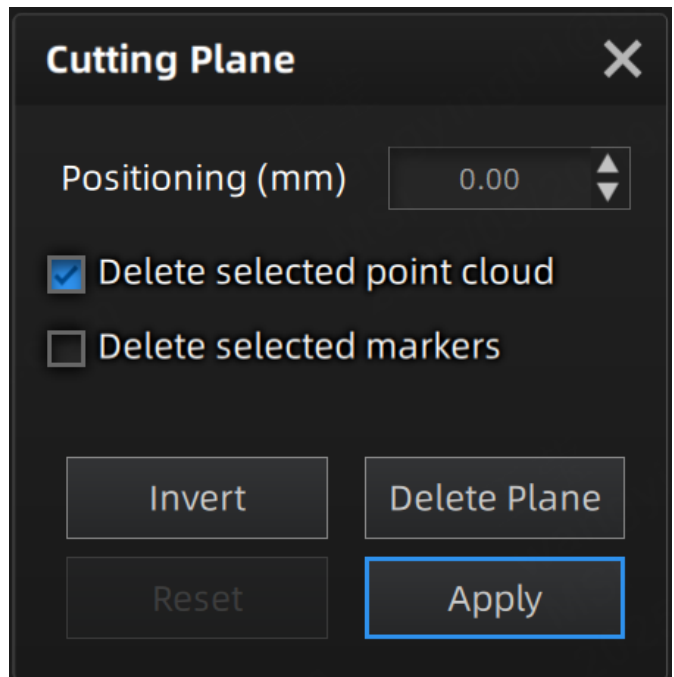

 **Caution**

- It is not supported to deleted all point clouds.
- At least four markers should be remained on the front of the cutting plane.
- Unable to uncheck **Delete the selected point cloud** in the current version.



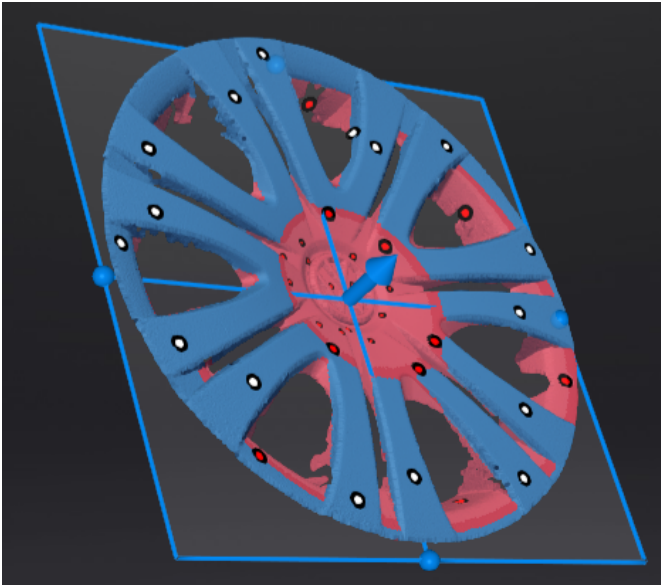



- **Invert:** Use this button to reverse the selection of data by flipping the cutting plane.
- **Delete plane:** Clicking this button will delete the current cutting plane and return to the interface for creating a new cutting plane.
- **Reset:** Reset all the operations performed after creating the cutting plane.
- **Apply:** Apply all the edits made.







- **Positioning:** The cutting plane can be translated in the following two ways:
 - Dragging the normal arrow on the cutting plane  to translate the cutting plane.
 - Entering the translation distance (unit:mm) in the value box to translate the cutting plane.
- **Rotation:** The cutting plane can be rotated by dragging the sphere on the cutting plane , using the opposite axis of the currently selected sphere as the center axis for rotation.

Right Sidebar

In the scanning interface, you can use more functions in the right sidebar.

Function	Description
 <p>Generate Point Cloud</p>	<p>End scanning and directly generate point cloud; hover the cursor over  to expand the function bar, where you can select Optimizing and Generating Point Cloud.</p>
 <p>Optimizing and Generating Point Cloud</p>	<p>First optimize the point cloud, then generate the overall point cloud. This process takes longer to compute and requires higher memory, but can solve most layering problems caused by cumulative errors, suitable for projects with higher accuracy requirements; hover the cursor over  to expand the function bar, where you can select Generate Point Cloud.</p>

Function	Description	Function	Description
 Project Group	Create or open a project group .	 Delete Your Scan	Delete the current data to rescan.
 Align	Align the data as needed.	 Export the Scan	Save the scanned data in the specified format locally.
 Mesh	Mesh your model.		

Shortcut



Shortcut	Function
Press and hold the <code>Left Button</code> and move the cursor	Rotate the data
Press and hold the <code>Middle Button</code> and move the cursor	Translate the data
Hold down <code>⇧ Shift</code> + <code>Left Button</code>	Select the area of data
Press and hold <code>^ Ctrl</code> + <code>Left Button</code>	Deselect the area of data
Scroll wheel	Zoom in or zoom out the data
<code>Spacebar</code>	Apply edits when editing data
Delete	Delete the selected data

Context Menu

Function	Description
Select all / Invert / Unselect / Delete selected data / Connected Domain	The function is the same as the function on editing toolbar , and can be operated by shortcut keys.
Fitting View	The data on the interface is displayed in the center according to the appropriate size; it can be operated by shortcut keys.
Set Rotate Center	The rotation center can be set on the data by the left mouse button.
Reset Rotate Center	Reset the rotation center back to the data center.
Bottom camera	Open or close the camera window.

Project Alignment

Click the  button in the right function panel of the scanning interface to enter the project alignment screen. This feature allows combining scanned data from multiple project files within the current project group into a complete 3D model, improving scanned data completeness.

Alignment Mode	Description	Alignment Mode	Description
 Auto Feature Alignment	Automatically aligns based on model features, suitable for scanned data with rich geometric features or when markers cannot be applied.	 Manual Feature Alignment	Aligns by manually selecting feature points on models. Use when auto feature alignment performs poorly.
 By Markers	Automatically aligns based on markers on models, suitable for marked model data.	 By Manual Markers	Aligns by manually selecting markers on models. Use when By Markers performs poorly.

Button	Description	Button	Description
Apply	Click to confirm alignment.	Next	Click to merge aligned projects into one group. This group can be further aligned with other projects.
Cancel	Click to undo alignment.	Exit	Click to exit alignment interface.

Function	Description	Function	Description
Pan Model	Hold mouse wheel and move cursor.	Rotate Model	Hold left mouse button and move cursor.
Zoom Model	Scroll mouse wheel to zoom.		

Auto Feature Alignment

1. Click  to select **Auto Feature Alignment** mode.
2. Choose projects to align in the fixed and floating windows on the left.

Note

Use zoom, rotate, and other operations in both windows as prompted on the left to inspect selected models.

3. Click **Apply** to automatically align projects in both windows based on shared features.

Note

Not suitable for objects with repetitive features (e.g., circular shapes) or very small objects.

Manual Feature Alignment

1. Click  to select **Manual Feature Alignment** mode.
2. Choose projects to align in the fixed and floating windows on the left.

Note

Use zoom, rotate, and other operations in both windows as prompted on the left to inspect selected models.

3. Hold  and click common feature points on models in both windows.
4. Click **Apply** to align projects based on selected feature points.

Note

- Selected feature points must not be colinear.
- Select at least 3 common feature points per project.



By Markers

1. Click  to select **By Markers** mode.
2. Choose projects to align in the fixed and floating windows on the left.

Note

Use zoom, rotate, and other operations in both windows as prompted on the left to inspect selected models.

3. Click **Apply** to automatically align projects based on shared markers.



By Manual Markers

1. Click  to select **By Manual Markers** mode.
2. Choose projects to align in the fixed and floating windows on the left.

Note

Use zoom, rotate, and other operations in both windows as prompted on the left to inspect selected models.

3. Hold  and click common markers on models in both windows.
4. Click **Apply** to align projects based on selected markers.

Note

- Selected markers must not be colinear.
- Select at least 3 common markers per project.



Post-Processing

Mesh

After generating the point cloud, click  on the right sidebar in the scanning interface to enter the post-processing interface, where the point cloud can be converted into the mesh.

Mesh Type

Choose different mesh types based on your requirements.

Function	Description
 Unwatertight	For models with unclosed holes, use this mesh type to keep the original state with less meshing time.
 Semi-watertight	Fill the holes automatically.
 Watertight	All holes will be filled automatically. The data can directly be 3D printed.

Mesh Optimization

After selecting the mesh type, you can continue to adjust the following parameters to optimize the mesh.

Filter

Optimize the data and improve the clarity of the data.

- Standard: Optimize data slightly and preserve data characteristics.
- Med: Reduce the noise on the surface of the scanned data.
- High: Reduce the noise on the surface of the scanned data and make the data smoother.

Smooth

Smooth the possible noise on the surface of the scanned data.

Remove Small Floating Parts

Delete any small disconnected data from the main data.

Simplification

Set the reduction level of the number of triangles in the mesh.

Note

- When the number of triangles removed during simplification exceeds the maximum number of triangles you set, the software will prioritize the simplification effect.
- In **Laser Scan**, select **Unwatertight Model** as the mesh type and then you can choose to enable **Intelligent Simplification**. The software will automatically set the degree of simplification based on the model.

Max Triangles

Set the maximum number of triangles for data simplification.

Note

Please enter a reasonable value to avoid excessive simplification that may result in a decrease in data quality.

Fill Small Hole

Automatically fill the small holes with a perimeter less than or equal to the value (10 mm by default) you set.

Remove Spike

Remove spike-like data on the edge.

Markers Hole Filling

Fill the surface holes on the data that are covered by markers before.

Recommended Parameters

When enabled, the software will automatically use the recommended parameters for meshing; when disabled, you can customize the parameters.

Buttons

Function	Description
Preview	Click this button to preview the effects of the applied settings.
	Click this button to discard the current settings and reset the preview effect.
Confirm	Click this button to apply the settings and enter the mesh editing interface.

Mesh Editing

After [mesh generation and optimization](#), you can further process the mesh using the tools of the sidebar and the editing toolbar of the Post-Processing interface.

Left Sidebar

Click **+** to expand the left sidebar.

Texture

Adjust the brightness and contrast of the texture to improve the texture effect.



Note

- The default value is 0, and the range is -100 to 100.
- This function is available for the project with textures.

Simplification

Set the reduction level of the number of triangles in the mesh.



Note

- The default value is 0, and the range is 0 to 99.
- Excessive simplification will cause the loss of some data details.

Mesh Optimization

Optimize the quality of the data by adding more triangles to curvature regions.

 **Note**

- The default value is 0, and the range is 0 to 100.
- The optimization time increases with the volume of data.

Smooth

Smooth the possible noise on the surface of the scanned data.

 **Note**

The default value is 0, and the range is 0 to 100.

Remove Small Floating Parts

Delete any small disconnected data from the main body data.

 **Note**

The default value is 0, and the range is 0 to 100.

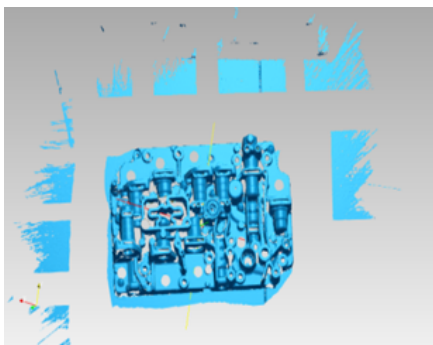

Original

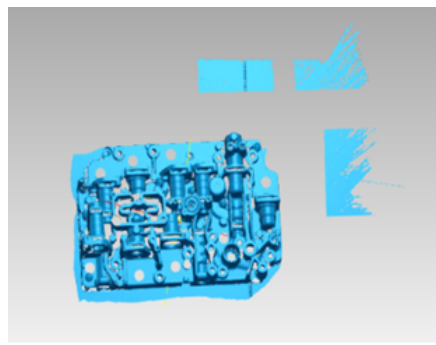

Remove 50

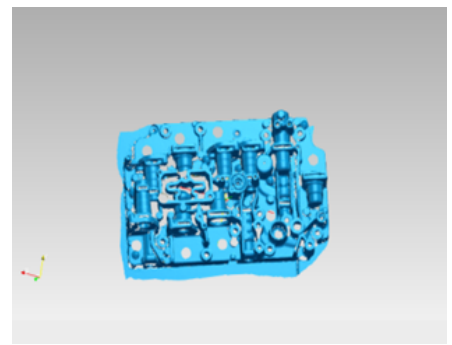

Remove 100

Auto Hole Filling

Fill every hole automatically whose perimeter is within the entered value (unit: mm).

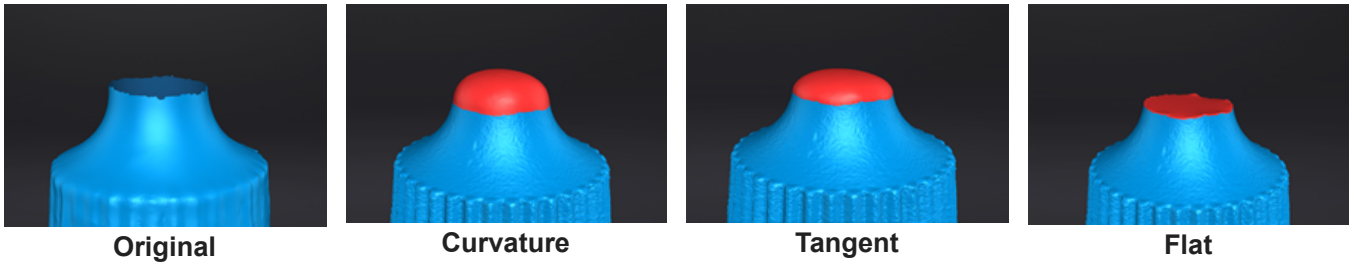

Manual Hole Filling

Fill the hole by clicking the edge of the hole.

Note

The edge of the hole to be filled is displayed green, and the filled hole is displayed red.

Flip Normal

To redefine the front direction of the scanned data in reversal engineering.

Note

- Use **⇧ Shift** + **Left Button** to select data.
- If you don't select an area, the normal of the entire data will be flipped.
- **Texture Remapping** should be performed first as it is unavailable after **Flip Normal**.

Cutting Plane Tool

Adjust the coordinate of the data with a custom plane as the bottom.

Note

Use **⇧ Shift** + **Left Button** to create a straight line and generate a plane.

Mirror

Draw a straight line as the central axis and perform a symmetrical copy.

Note

Use **↑ Shift** + **Left Button** to create a central axis.

Zoom

Adjust the scaling ratio of the model.

Note



The default value is 100, which means to maintain the original size.

Buttons

Button	Description	Note
	Resetting the preview effect.	It is unavailable in Cutting Plane Tool and Zoom .
Apply	Applying the operation.	/
Cancel	Undoing the operation and exit.	/

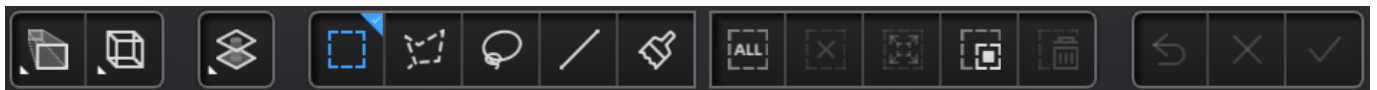
Editing Toolbar













功能	描述
 Select Visible	Selecting visible data on the front view only.
 Select Through	Selecting the visible area and the data behind it at the same time.

 **Note**



To learn more, see [Editing Toolbar](#).

Right Sidebar





Function	Description
 Mesh	Reopen the mesh panel to regenerate the mesh.  Note If the mesh is imported locally, this function is not available.
 Open File	Open a project for post-processing.
 Export Your Scan	 : Save the scanned data in the specified format locally.  : If you have installed EXModel, clicking this button will switch to EXModel, and the data will be automatically imported.
 Share Your Scan	<ul style="list-style-type: none">• Sharing your model to Sketchfab [🔗].• Uploading your model to SHINING 3D Digital Cloud [🔗].
 Texture Remapping	Refine texture misalignment issues after mesh optimization and mesh editing.  Note <ul style="list-style-type: none">• If hole filling or simplification is applied, remap the texture before saving the data.• If you are going to process the texture in a third-party software, click Texture Layout Optimization to create an optimized arrangement which will make the texture editing much more convenient.
 Show Texture / Hide Texture	Toggle model texture visibility.
 Model Display	After clicking the button or press F12 , the model will be displayed in rotation, and the rotation speed can be adjusted by clicking . Press F12 again or Esc to exit the model display interface. The model is only displayed in the clockwise rotation at the current viewing angle. If you need to display other angles, please exit and adjust the display angle in the Post-Processing interface.

Measurement











Measurement

After completing [mesh optimization](#), click  in the corresponding position of the navigation bar to enter the measurement interface, where you can perform operations such as **creating features**, **alignment**, and **measurement**. Alternatively, you can directly click  in the navigation bar from any interface to access the measurement interface. Click  on the right-side function panel or drag and drop project files to import models (including third-party 3D models) for measurement.

Interface Operations

Function	Instructions
Rotation	Hold the left mouse button and move the cursor to rotate the model.
Movement	Hold the middle mouse button and move the cursor to move the model.
Zoom In/Out	Scroll the mouse wheel up or down to zoom in or out.
Zoom to Fit	Click this option in the right-click menu or press  +  to center and resize the data to fit the view.
Set Rotation Center	By default, the rotation center is the data center. Click this option in the right-click menu or press  +  , then click any point on the data to set it as the new rotation center. Press  to cancel.
Reset Rotation Center	Click this option in the right-click menu to reset the rotation center to the data center.

Right Sidebar

Function	Description
 Open File	Open a project for measurement.
 Export Your Scan	 : Save the scanned data in the specified format locally.  : If EXModel is installed, clicking this button will switch to EXModel, and the data will be automatically imported.
 Share Your Scan	<ul style="list-style-type: none"> Share your model to Sketchfab [🔗]. Upload your model to SHINING 3D Digital Cloud [🔗].
 Create Feature	Click to enter feature creation mode for measurement. See Creating Features for details.
 Align	Click to align the model with the coordinate system. See Model Alignment for details.
 Measure	Click to measure distance, surface area, and volume. See Model Measurement for details.
 Multi-View	View the model from multiple angles during feature creation, alignment, or measurement.
 Show Texture / Hide Texture	Toggle model texture visibility.

Creating Features

On the right side of the measurement interface, click  to open the create feature window, where you can create feature points, lines, and planes for the model.

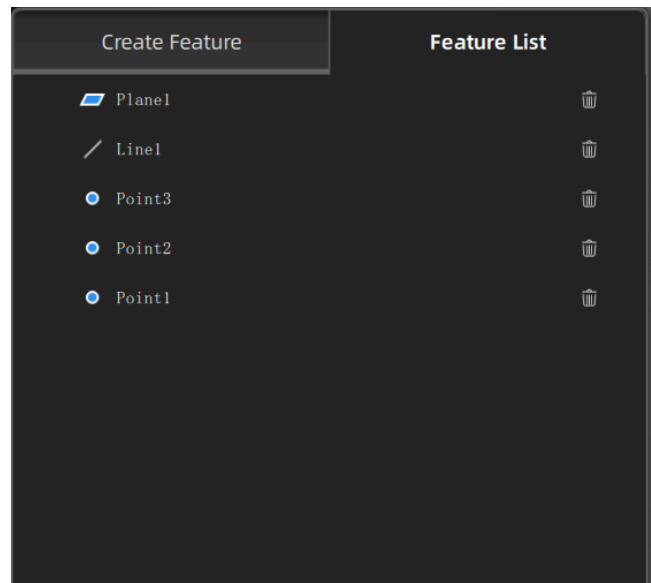
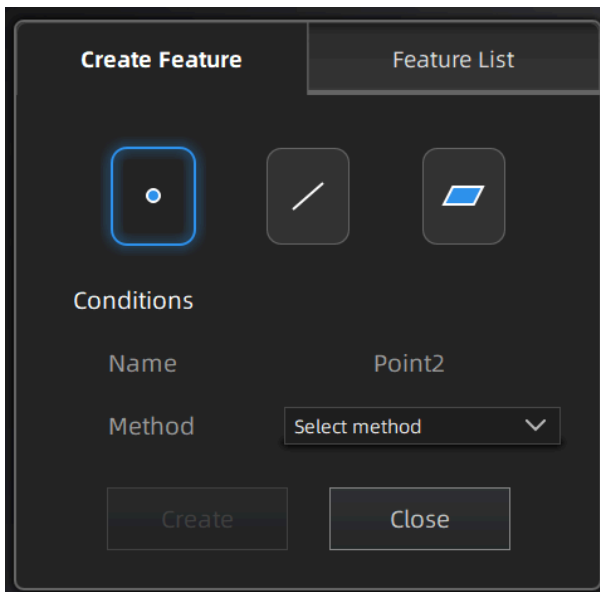

Note

You can switch to the **Feature List** to view created features; click  to delete created features.

Feature Point

You can create feature points using either the **Points** or **Line-Plane Intersection** method.

Points

1. Choose **Points** as the creation method.
2. Click on the model to select points.
3. Click **Create** to generate a single feature point.

Note

If you do not click **Create** after selecting a point, you can click elsewhere on the model to reselect.

Line-Plane Intersection

1. Choose **Line-Plane Intersection** as the creation method.
2. Click on a created feature line on the model, or select one from the line dropdown list.
3. Click on a created feature plane on the model, or select one from the plane dropdown list.
4. Click **Create** to generate a single feature point.

Note

- You cannot select feature lines that lie on feature planes.
- You cannot select parallel feature lines and planes.
- This method requires pre-created feature lines and planes.

Feature Line

Point-Point

1. Choose **Point-Point** as the creation method.
2. Select two points by clicking anywhere on the data or by selecting created feature points.

Note

Under **Selection**, you can click **From** or **To** to reselect points.

3. Click **Create** to generate a single feature line.

Plane-Plane Intersection

1. Choose **Plane-Plane Intersection** as the creation method.
2. Click on created feature planes on the model, or select them from the plane dropdown list.
3. After selecting two planes, click **Create** to generate a single feature line.

Note

- You cannot select two parallel feature planes.
- This method requires at least two pre-created feature planes.
- Before clicking **Create**, you can click **Plane** under **Selection** to reselect planes.

Feature Plane

3 Points Fit

1. Choose **3 Points Fit** as the creation method.
2. Select three points by clicking anywhere on the data or by selecting created feature points.

Note

- The three selected points must not be colinear.
- Under **Selection**, you can click **Point 1** / **Point 2** / **Point 3** to reselect points.

3. Click **Create** to generate a single feature plane.

Point-Line Fit

1. Choose **Point-Line Fit** as the creation method.
2. Click on a created feature line on the model, or select one from the line dropdown list.
3. Select a point by clicking anywhere on the data or by selecting a created feature point.
4. Click **Create** to generate a single feature plane.

Note

- The selected point must not lie on the selected feature line.
- Before clicking **Create**, you can click **Line** / **Point** under **Selection** to reselect.

Best Fit

Use the selection tool in the editing toolbar to select data, then click **Create** to generate a single feature plane. The resulting plane minimizes deviation from the selected area.

Note

For details about the editing toolbar, see [Point Cloud Editing](#).

Model Alignment

Click  to open the alignment window. This function allows adjusting the spatial coordinates of data for easier post-processing or reverse engineering.

Caution

- Aligning models does not affect data shape or accuracy.
- Once a model is aligned to a new position and the alignment function is exited, you can only restore its previous position by reloading the project file.

Precise Alignment

Achieve accurate alignment between models and coordinate systems by entering precise values.

Note

You can enable the **global coordinate system**. When enabled, the interface will display the global coordinate system with red indicating the positive X-axis direction, green for positive Y-axis, and blue for positive Z-axis.

1. Use  multi-view function or pan/rotate the model to check different viewing angles and verify if the placement meets requirements.
2. Determine the translation or rotation axis (X, Y, or Z axis), enter corresponding values, then click **Move To**.
3. Repeat step 2 until suitable rotation values are identified.
4. After adjusting one direction, click **Close** to exit the alignment window and save adjustments.
5. Re-enter the alignment window and repeat steps 2-4 until the model placement meets requirements across different viewing angles.

3-2-1 Coordinate System Alignment

3-2-1 Coordinate System Alignment aligns data through point, line, and plane constraints. Before alignment, use  **Create Feature** to establish feature points, lines, and planes.

Note

The coordinate system displayed represents the global coordinate system, with red indicating positive X-axis, green for positive Y-axis, and blue for positive Z-axis.

1. Select a feature plane from the plane dropdown menu, then choose an axis from the corresponding constraint dropdown. The arrow on the plane corner indicates its positive direction and the selected axis direction will match the plane's orientation.
2. Select a feature line from the line dropdown menu, then choose an axis from the corresponding constraint dropdown. The line's arrow indicates its positive direction and the selected axis direction will match the projection direction of the line on the chosen plane.

3. Select a point from the point dropdown menu and this point's position will become the coordinate origin (0,0,0).
4. Click **Align** to perform coordinate axis transformation; click **Reset** to restore the coordinate system, undoing all transformations made since entering the 3-2-1 alignment interface.

 **Note**

Avoid selecting perpendicular feature lines and planes for alignment to prevent failure.

5. After alignment, click **Close** to confirm the transformation and exit the alignment interface.

Quick Alignment

Quickly align coordinate systems by adjusting model angles.

1. Rotate the model to the desired angle.
2. Click **Align** to move the coordinate frame to the model's center with X-axis perpendicular to screen, Y-axis parallel to screen pointing right, and Z-axis parallel to screen pointing up (model position remains unchanged). Click **Move** to position the coordinate frame at the object's bottom center.
3. After alignment, click **Close** to apply the adjusted coordinate frame and exit alignment. If unsatisfied with results, click **Reset** to restore the coordinate frame to its initial state for re-alignment.

Measurement Tools

In the right function panel of the measurement interface, click  to open the measurement window, where you can calculate the surface distance between points, the surface area of selected data, and the volume of enclosed data.

Distance

When you select two points on the data, the straight-line distance between those two points will be automatically calculated.

 **Note**

- **Total value** represents the 3D distance.
- **X value**, **Y value**, and **Z value** are the projection lengths of the line segment formed by the two points onto each coordinate plane.
- You can click to select **First point** / **Second point** to reselect points.

Surface Area

After selecting data using the selection tool or shortcut keys, click **Calculate** to compute the area of the selected surface region, measured in square millimeters (mm²).

 **Note**

- Point clouds or markers cannot be used for surface area calculation.
- For detailed information about selection tools and shortcut keys, refer to [Point Cloud Editing](#).

Volume

When entering the volume measurement function, the overall volume of the data and its bounding box coordinates (the smallest axis-aligned box enclosing the data) will be automatically displayed, with volume measured in cubic millimeters (mm³).

 **Note**



Only closed mesh models support volume measurement.

Save and Share

The processed model files can be exported or shared.

Save Model



The model can be exported locally or to EXModel.

- Click  >  to select the save path and the file format, enter the file name as well.

Format	Data Type	Saved as	Application
ASC (whole scan)	Optimized point cloud	Scan.asc	<ul style="list-style-type: none"> Data viewing and analysis. Further data processing, registration, etc in other software.
STL	Mesh	Scan.stl	<ul style="list-style-type: none"> 3D printing. Reverse engineering. Further editing, rendering, etc. in other 3D modeling or rendering software.
PLY	Mesh	Scan.ply	Further editing, rendering, etc. in other 3D modeling or rendering software.
OBJ	Mesh	Scan.obj Scan.jpg Scan.mtl	<ul style="list-style-type: none"> 3D printing. Data conversion and sharing in different platforms.
3MF	Mesh	Scan.3mf	<ul style="list-style-type: none"> 3D printing. Data conversion and sharing in different platforms. Further editing, rendering, etc. in other 3D modeling or rendering software.
P3	Global markers	Scan.p3	Quickly importing the global markers and the cutting plane (if any) together into the scanning interface to assist with the scanning process.



Note

When saving the file in .p3 format, complete the optimization  after scanning.

- Click  >  to switch to EXModel, and the data will be automatically imported.

Share Model

Upload to Sketchfab



Click  >  and upload the data to [Sketchfab](#)[🔗], where the title, username and password are required to be provided. You can register an account on the Sketchfab to view the shared models.

 **Caution**

The uploaded files are in STL format.

Upload to SHINING 3D Digital Cloud

Support uploading the mesh to SHINING 3D Digital Cloud.

Click  > , enter the model name and select the file format to upload the data to SHINING 3D Digital Cloud; after successful upload, click **Preview** to go to the digital cloud to view the uploaded model.

 **Note**

- Supports uploading OBJ, PLY, and STL file formats.
- The cloud node is automatically assigned, please log in to the specified node to view shared models.
- Only supports uploading data files smaller than 500 MB at a time; if the file is too large, please simplify it in advance.

Version History

Einstar Rockit historical version user manuals are listed below; click [here](#) to view the latest version user manual.

V1.0.5

[Einstar Rockit User Manual V1.0.5](#)

V1.0.4

[Einstar Rockit User Manual V1.0.4](#)

V1.0.3

[Einstar Rockit User Manual V1.0.3](#)

V1.0.2

[Einstar Rockit User Manual V1.0.2](#)

V1.0.1

[Einstar Rockit User Manual V1.0.1](#)

V1.0.0

Contact

Email: einscan_support@shining3d.com 

Support platform: <https://support.einscan.com> 

SHINING 3D Offices

APAC Region & Headquarters

SHINING 3D Tech Co., Ltd.

Hangzhou, China

Phone: +86 571 82999050

Add: No. 1398, Xiangbin Road, Wenyan, Xiaoshan, Hangzhou,
Zhejiang, China, 311258

EMEA Region

SHINING 3D Technology GmbH.

Stuttgart, Germany

Phone: +49 711 28444089

Add: Breitwiesenstraße 28, 70565, Stuttgart, Germany

Americas Region

SHINING 3D Technology Inc.

San Leandro, United States

Phone: +1 (888) 597-5655

Add: 2450 Alvarado St #7, San Leandro, CA 94577